

PLAN SET 11 CONSTRUCTION ACTIVITIES

EAST WEST LINK DRAWING REGISTER						
DWG NUMBER	DRAWING TITLE	CURRENT REVISION	DATE AND REVISION			
			1/12/2016	14/12/2016	7/04/2017	23/05/2017
	PLAN SET 11 - CONSTRUCTION ACTIVITIES					
AEE-CA-001	CONSTRUCTION ACTIVITIES - EAST WEST LINK - DRAWING INDEX, NOTES AND LEGEND	2	0	1		2
AEE-CA-100	CONSTRUCTION ACTIVITIES - EAST WEST LINK - OVERVIEW PLAN	2	0	1		2
AEE-CA-101	CONSTRUCTION ACTIVITIES - SH20/NEILSON STREET INTERCHANGE - SHEET 1	1	0			1
AEE-CA-102	CONSTRUCTION ACTIVITIES - NEILSON STREET INTERCHANGE - SHEET 2	1	0			1
AEE-CA-103	CONSTRUCTION ACTIVITIES - EAST WEST LINK/GALWAY STREET - SHEET 3	1	0			1
AEE-CA-104	CONSTRUCTION ACTIVITIES - EMBANKMENT - SHEET 4	1	0			1
AEE-CA-105	CONSTRUCTION ACTIVITIES - EMBANKMENT - SHEET 5	1	0			1
AEE-CA-106	CONSTRUCTION ACTIVITIES - EMBANKMENT/ANNS CREEK - SHEET 6	1	0			1
AEE-CA-107	CONSTRUCTION ACTIVITIES - ANNS CREEK - SHEET 7	2	0	1		2
AEE-CA-108	CONSTRUCTION ACTIVITIES - ANNS CREEK/SYLVA PARK ROAD - SHEET 8	2	0	1		2
AEE-CA-109	CONSTRUCTION ACTIVITIES - ANNS CREEK/SYLVA PARK RAMPS - SHEET 9	2	0	1		2
AEE-CA-110	CONSTRUCTION ACTIVITIES - SH1/SYLVA PARK RAMPS - SHEET 10	1	0			1
AEE-CA-111	CONSTRUCTION ACTIVITIES - SH1/PANAMA ROAD - SHEET 11	1	0			1
AEE-CA-112	CONSTRUCTION ACTIVITIES - SH1/OTAHUHU CREEK - SHEET 12	1	0			1
AEE-CA-113	CONSTRUCTION ACTIVITIES - PRINCES STREET INTERCHANGE - SHEET 13	1	0			1
AEE-CA-114	CONSTRUCTION ACTIVITIES - NEILSON STREET INTERCHANGE - LOCAL ROADS - SHEET 14A AND 14B	1	0			1
AEE-CA-115	CONSTRUCTION ACTIVITIES - CAPTAIN SPRINGS ROAD/ PORTS LINK - SHEET 15A AND 15B	1	0			1
AEE-CA-116	CONSTRUCTION ACTIVITIES - EMBANKMENT - SHEET 16	1	0			1
AEE-CA-201	CONSTRUCTION ACTIVITIES - SH1/PANAMA ROAD - BRIDGE STAGING PLAN	1	0			1
AEE-CA-202	CONSTRUCTION ACTIVITIES - SH1/OTAHUHU CREEK - BRIDGE STAGING PLAN	1	0			1
AEE-CA-203	CONSTRUCTION ACTIVITIES - PRINCES STREET INTERCHANGE - BRIDGE STAGING PLAN	1	0			1

LEGEND: CONSTRUCTION ACTIVITIES

PROPOSED FEATURES	
CONSTRUCTION YARDS BUILDING TO BE REMOVED TEMPORARY TRAFFIC DIVERSION DREDGING TRENCH BRIDGE STAGING TEMPORARY TOWERS TEMPORARY PATH DESIGNATION BOUNDARY OCCUPATION OF COASTAL MARINE AREA (PERMANENT) TEMPORARY OCCUPATION AREA (WITHIN THE CMA)	CUT SLOPES ROAD ALIGNMENT FILL SLOPES TOE OF OUTER BUND BRIDGE STRUCTURE CYCLE/ PEDESTRIAN PATH RETAINING WALL AREA OF TEMPORARY OCCUPATION OVERLAND FLOW CHANNEL
EXISTING FEATURES	
PROPERTY BOUNDARY EXISTING SHARED PATH TO REMAIN	EXISTING COASTAL MARINE BOUNDARY

CONSTRUCTION ACTIVITIES PLANS, REFER DRAWINGS TRS-CA-101 TO TRS-CA-116

2	BOARD OF INQUIRY	RT	NN	JC	27.06.2017
1	ISSUED FOR CONSENT - GSR GRADE SEPARATION	AR	NN*	PK*	14.12.2016
0	ISSUED FOR CONSENT	AR	NN*	PK*	01.12.2016
No.	Issued Status	Drawn	Check'd	App'd	Date

DISCLAIMER
 This drawing is for the purpose of supporting applications under the RMA for resource consents and designations. All information shown is subject to final design. Areas and measurements are subject to survey. Where the designs conflict with conditions the conditions will prevail. This Drawing **must not** be used for construction



Drawn A RAM	Drafting Check J MURAHIDY	Reviewed Design Manager N NANCEKIVELL	Approved Alliance Manager J CALDWELL
Designed L COLLINS	Design Check J MURAHIDY	27.06.17	27.06.17
Scale: Original Scale (A1)		Reduced Scale (A3)	AS SHOWN
Contract No			PA4014

Drawing Title CONSTRUCTION ACTIVITIES EAST WEST LINK DRAWING INDEX, NOTES AND LEGEND	Rev No. 2
Drawing Number AEE-CA-001	

FOR BOI ISSUE

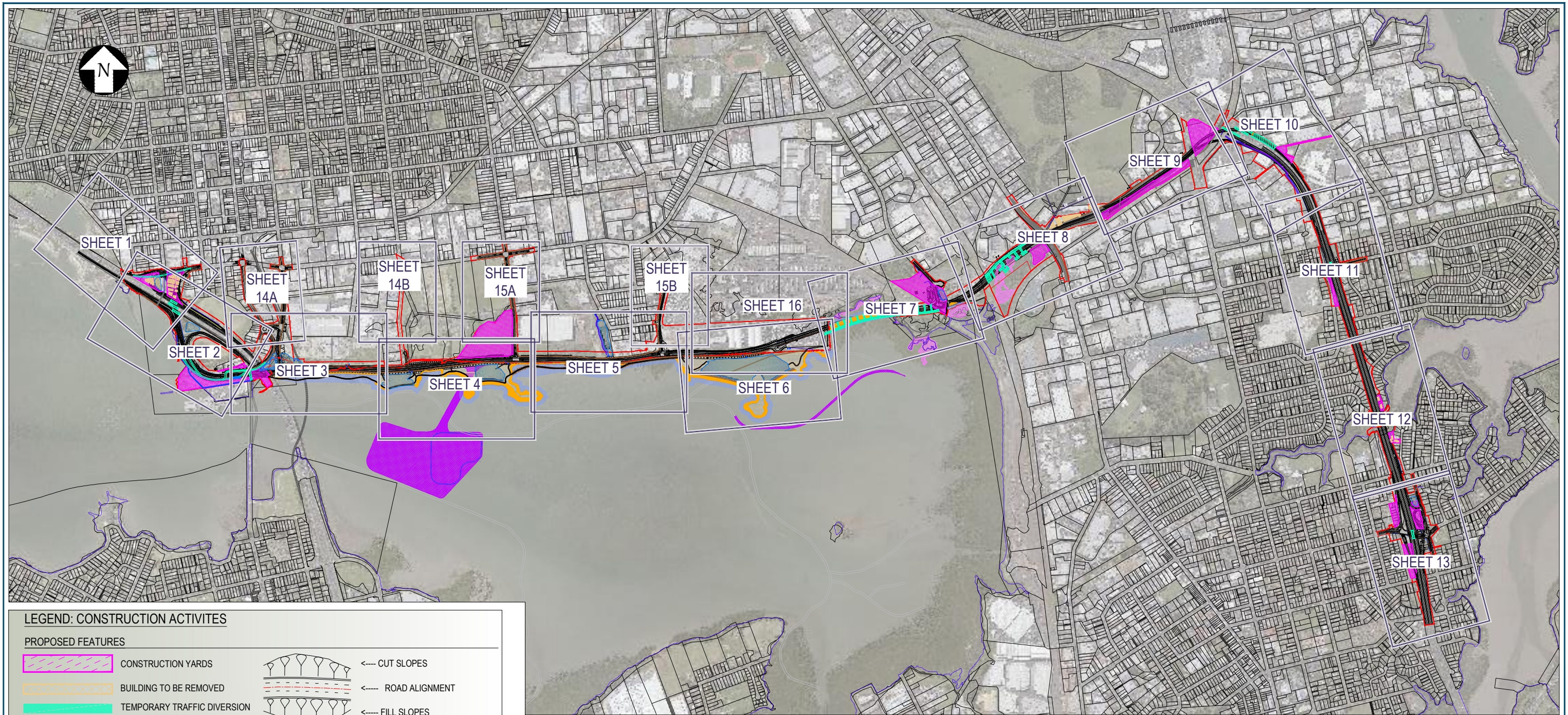

LEGEND: CONSTRUCTION ACTIVITES

PROPOSED FEATURES

- | | | | |
|--------------------------|---|--|----------------------------------|
| | CONSTRUCTION YARDS | | CUT SLOPES |
| | BUILDING TO BE REMOVED | | ROAD ALIGNMENT |
| | TEMPORARY TRAFFIC DIVERSION | | FILL SLOPES |
| | DREDGING TRENCH | | TOE OF OUTER BUND |
| | BRIDGE STAGING | | BRIDGE STRUCTURE |
| | TEMPORARY TOWERS | | CYCLE/ PEDESTRIAN PATH |
| | TEMPORARY PATH | | RETAINING WALL |
| | DESIGNATION BOUNDARY | | AREA OF TEMPORARY OCCUPATION |
| | OCCUPATION OF COASTAL MARINE AREA (PERMANENT) | | OVERLAND FLOW CHANNEL |
| | TEMPORARY OCCUPATION AREA (WITHIN THE CMA) | | EXISTING COASTAL MARINE BOUNDARY |
| EXISTING FEATURES | | | |
| | PROPERTY BOUNDARY | | EXISTING COASTAL MARINE BOUNDARY |
| | EXISTING SHARED PATH TO REMAIN | | |

CONSTRUCTION ACTIVITIES PLANS, REFER DRAWINGS TRS-CA-101 TO TRS-CA-116



2	BOARD OF INQUIRY	RT	NN	JC	27.06.2017
1	ISSUED FOR CONSENT - GSR GRADE SEPARATION	AR	NN*	PK*	14.12.2016
0	ISSUED FOR CONSENT	AR	NN*	PK*	01.12.2016
No.	Issued Status	Drawn	Check'd	App'd	Date

DISCLAIMER
 This drawing is for the purpose of supporting applications under the RMA for resource consents and designations. All information shown is subject to final design. Areas and measurements are subject to survey. Where the designs conflict with conditions the conditions will prevail. This Drawing **must not** be used for construction



Drawn	A RAM	Drafting Check	J MURAHIDY	Reviewed Design Manager	N NANCEKIVELL	Approved Alliance Manager	J CALDWELL
Designed	L COLLINS	Design Check	J MURAHIDY		27.06.17		27.06.17
Scale:	Original Scale (A1)	Reduced Scale (A3)	AS SHOWN	Contract No	PA4014		

Drawing Title	CONSTRUCTION ACTIVITES EAST WEST LINK OVERVIEW PLAN		
Drawing Number	AEE-CA-100	Rev No.	2



INDICATIVE CONSTRUCTION STAGING FOR NEILSON STREET OVERBRIDGE:

STAGE 1, 2 AND 3:
 1.1 REALIGN SH20 TO PROVIDE WORK AREA FOR BRIDGE PIER CONSTRUCTION.
 1.2 CONSTRUCT PILES, PILE CAP, COLUMNS AND PIER CAP.

STAGE 4:
 4.1 CONSTRUCT REMAINING PIERS AND ABUTMENTS.

STAGE 5:
 5.1 ERECT BRIDGE BEAMS WITH NIGHT CLOSURE.

STAGE 6:
 6.1 COMPLETE SUPERSTRUCTURE

NOTE:
 PIER LOCATIONS ARE INDICATIVE AND WILL BE FINALISED AT DETAILED DESIGN.

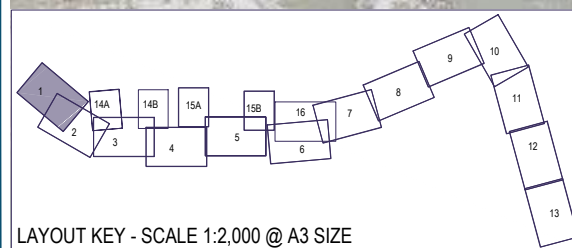
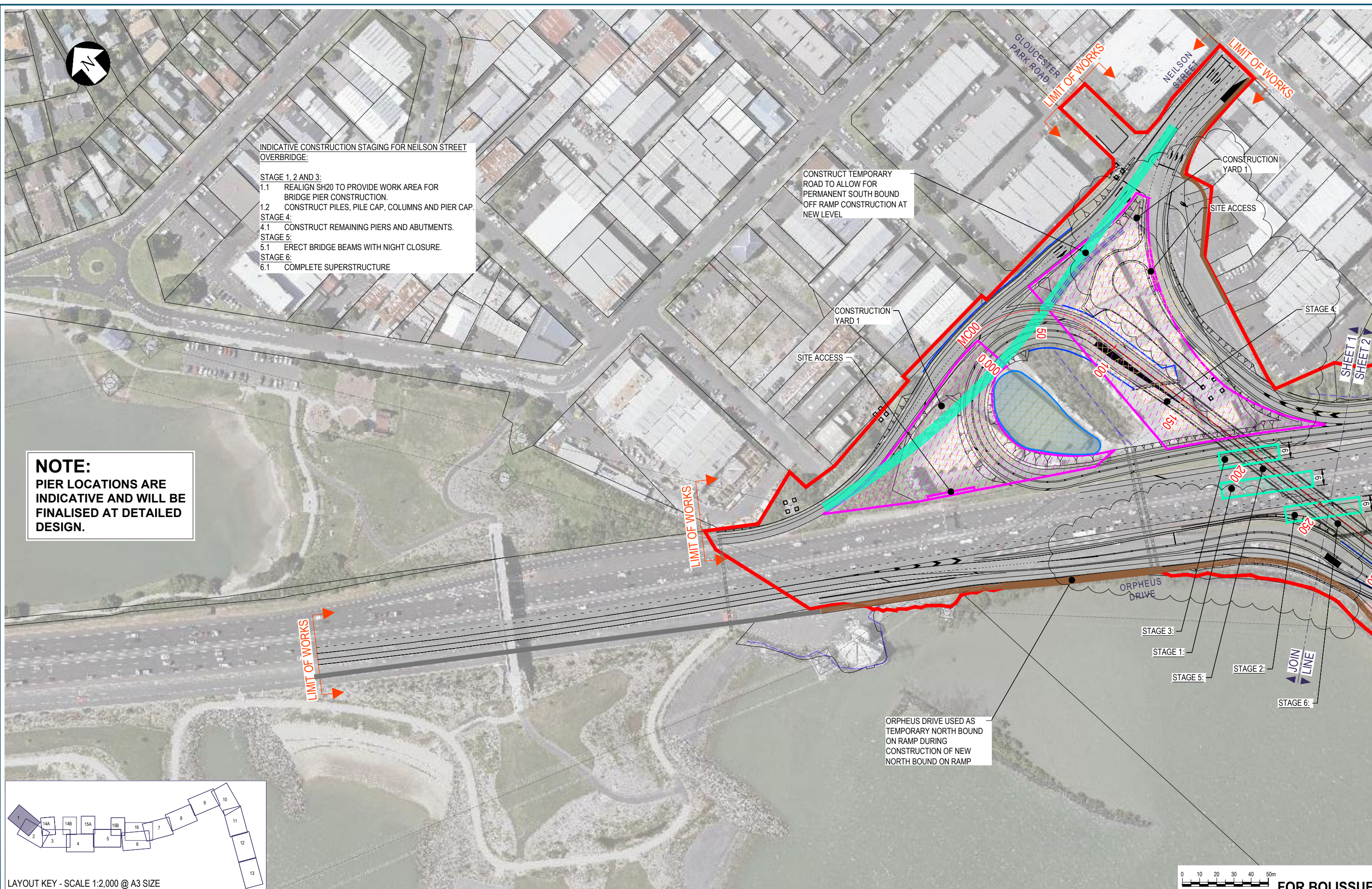

0 10 20 30 40 50m
 SCALE 1:2,000 @ A3 SIZE **FOR BOI ISSUE**

No.	Issued Status	Drawn	Check'd	App'd	Date
1	BOARD OF INQUIRY	RT	NN	JC	27.06.2017
0	ISSUED FOR CONSENT	AR	NN*	PK*	01.12.2016

DISCLAIMER
 This drawing is for the purpose of supporting applications under the RMA for resource consents and designations. All information shown is subject to final design. Areas and measurements are subject to survey. Where the designs conflict with conditions the conditions will prevail. This Drawing **must not** be used for construction

Drawn	A RAM	Drafting Check	J MURAHIDY	Reviewed Design Manager	N NANCEKIVELL	Approved Alliance Manager	J CALDWELL
Designed	L COLLINS	Design Check	J MURAHIDY		27.06.17		27.06.17
Scale:	Original Scale (A1)	Reduced Scale (A3)	AS SHOWN	Contract No	PA4014		

Drawing Title	CONSTRUCTION ACTIVITIES NEILSON STREET INTERCHANGE SHEET 01		
Drawing Number	AEE-CA-101	Rev No.	1

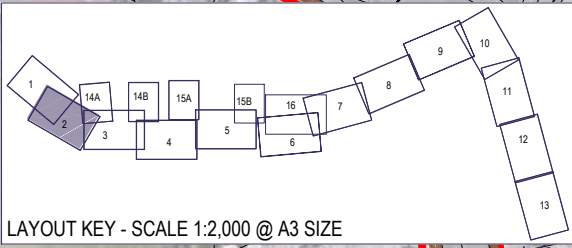
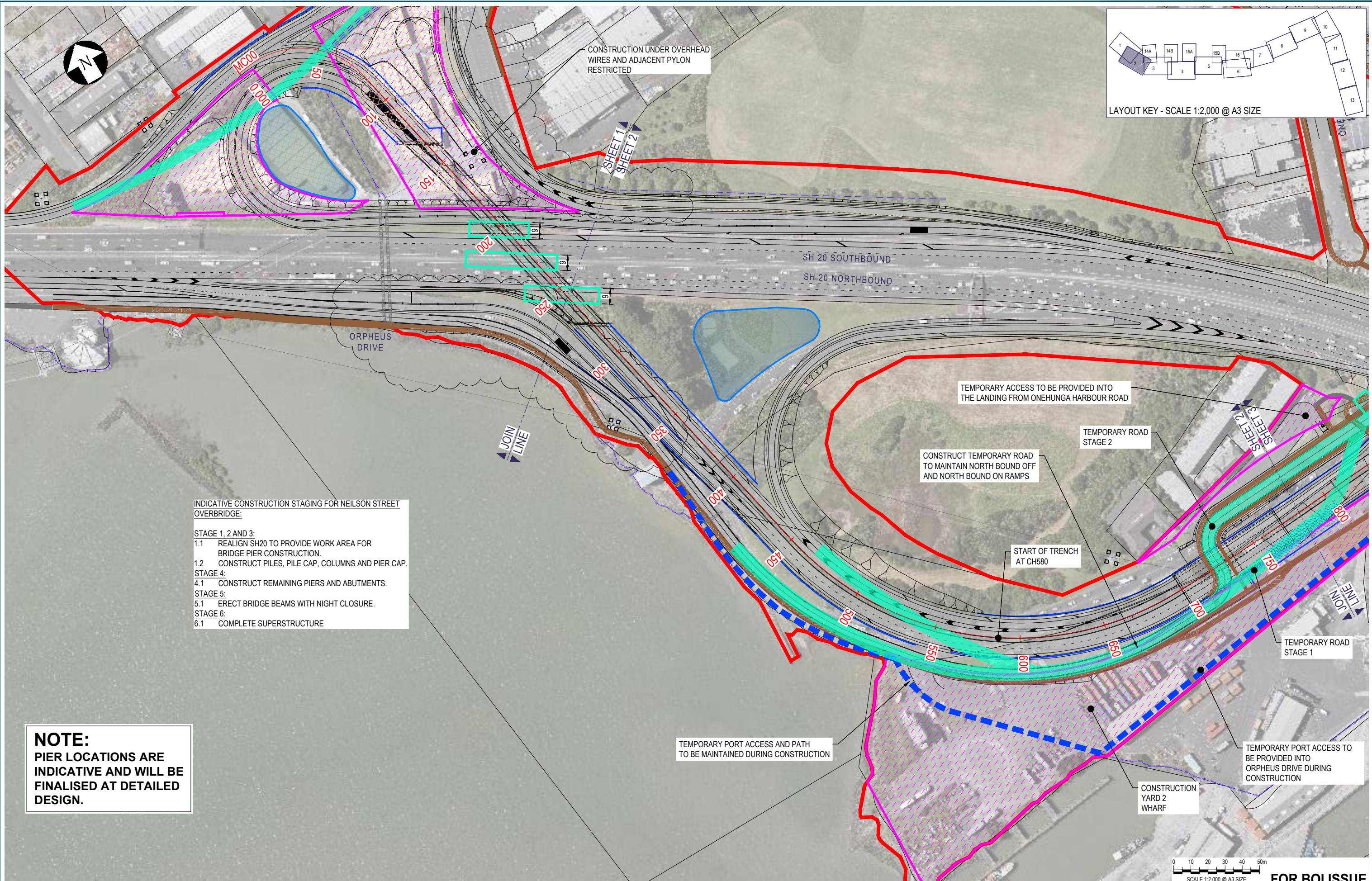

INDICATIVE CONSTRUCTION STAGING FOR NEILSON STREET OVERBRIDGE:

STAGE 1, 2 AND 3:

1.1 REALIGN SH20 TO PROVIDE WORK AREA FOR BRIDGE PIER CONSTRUCTION.

1.2 CONSTRUCT PILES, PILE CAP, COLUMNS AND PIER CAP.

STAGE 4:

4.1 CONSTRUCT REMAINING PIERS AND ABUTMENTS.

STAGE 5:

5.1 ERECT BRIDGE BEAMS WITH NIGHT CLOSURE.

STAGE 6:

6.1 COMPLETE SUPERSTRUCTURE

NOTE:
PIER LOCATIONS ARE INDICATIVE AND WILL BE FINALISED AT DETAILED DESIGN.

No.	Issued Status	Drawn	Check'd	App'd	Date
1	BOARD OF INQUIRY	RT	NN	JC	27.06.2017
0	ISSUED FOR CONSENT	AR	NN*	PK*	01.12.2016

DISCLAIMER
This drawing is for the purpose of supporting applications under the RMA for resource consents and designations. All information shown is subject to final design. Areas and measurements are subject to survey. Where the designs conflict with conditions the conditions will prevail. This Drawing **must not** be used for construction

Drawn A RAM	Drafting Check J MURAHIDY	Reviewed Design Manager N NANCEKIVELL	Approved Alliance Manager J CALDWELL
Designed L COLLINS	Design Check J MURAHIDY	27.06.17	27.06.17
Scale: Original Scale (A1)	Reduced Scale (A3)	AS SHOWN	Contract No PA4014

Drawing Title CONSTRUCTION ACTIVITIES NEILSON STREET INTERCHANGE SHEET 02	Drawing Number AEE-CA-102	Rev No. 1
--	------------------------------	--------------

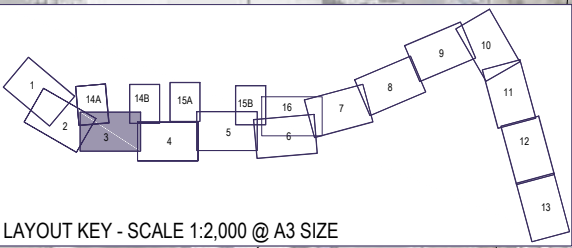
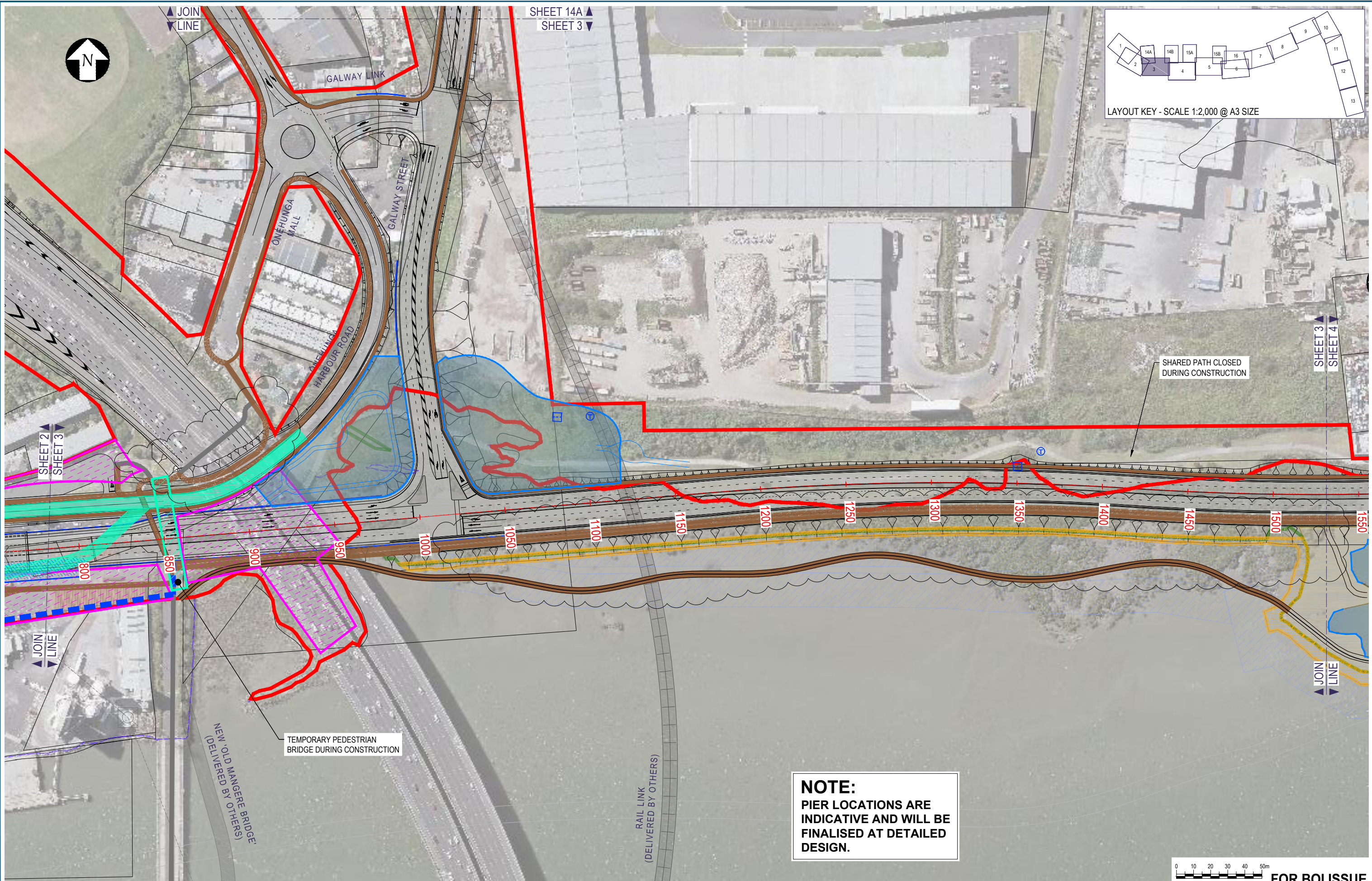

NOTE:
PIER LOCATIONS ARE
INDICATIVE AND WILL BE
FINALISED AT DETAILED
DESIGN.

0 10 20 30 40 50m
SCALE 1:2,000 @ A3 SIZE **FOR BOI ISSUE**

No.	Issued Status	Drawn	Check'd	App'd	Date
1	BOARD OF INQUIRY	RT	NN	JC	27.06.2017
0	ISSUED FOR CONSENT	AR	NN*	PK*	01.12.2016

DISCLAIMER
This drawing is for the purpose of supporting applications under the RMA for resource consents and designations. All information shown is subject to final design. Areas and measurements are subject to survey. Where the designs conflict with conditions the conditions will prevail. This Drawing **must not** be used for construction

Drawn	A RAM	Drafting Check	J MURAHIDY	Reviewed Design Manager	N NANCEKIVELL	Approved Alliance Manager	J CALDWELL
Designed	L COLLINS	Design Check	J MURAHIDY		27.06.17		27.06.17
Scale:	Original Scale (A1)	Reduced Scale (A3)	AS SHOWN	Contract No	PA4014		

Drawing Title	CONSTRUCTION ACTIVITIES EAST WEST LINK/ GALWAY STREET SHEET 03		
Drawing Number	AEE-CA-103	Rev No.	1

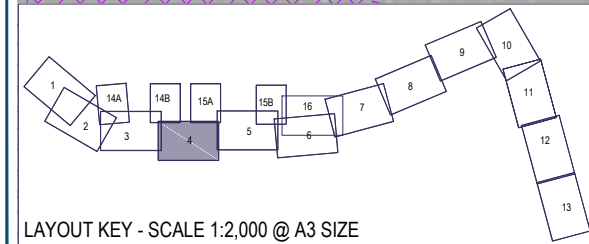
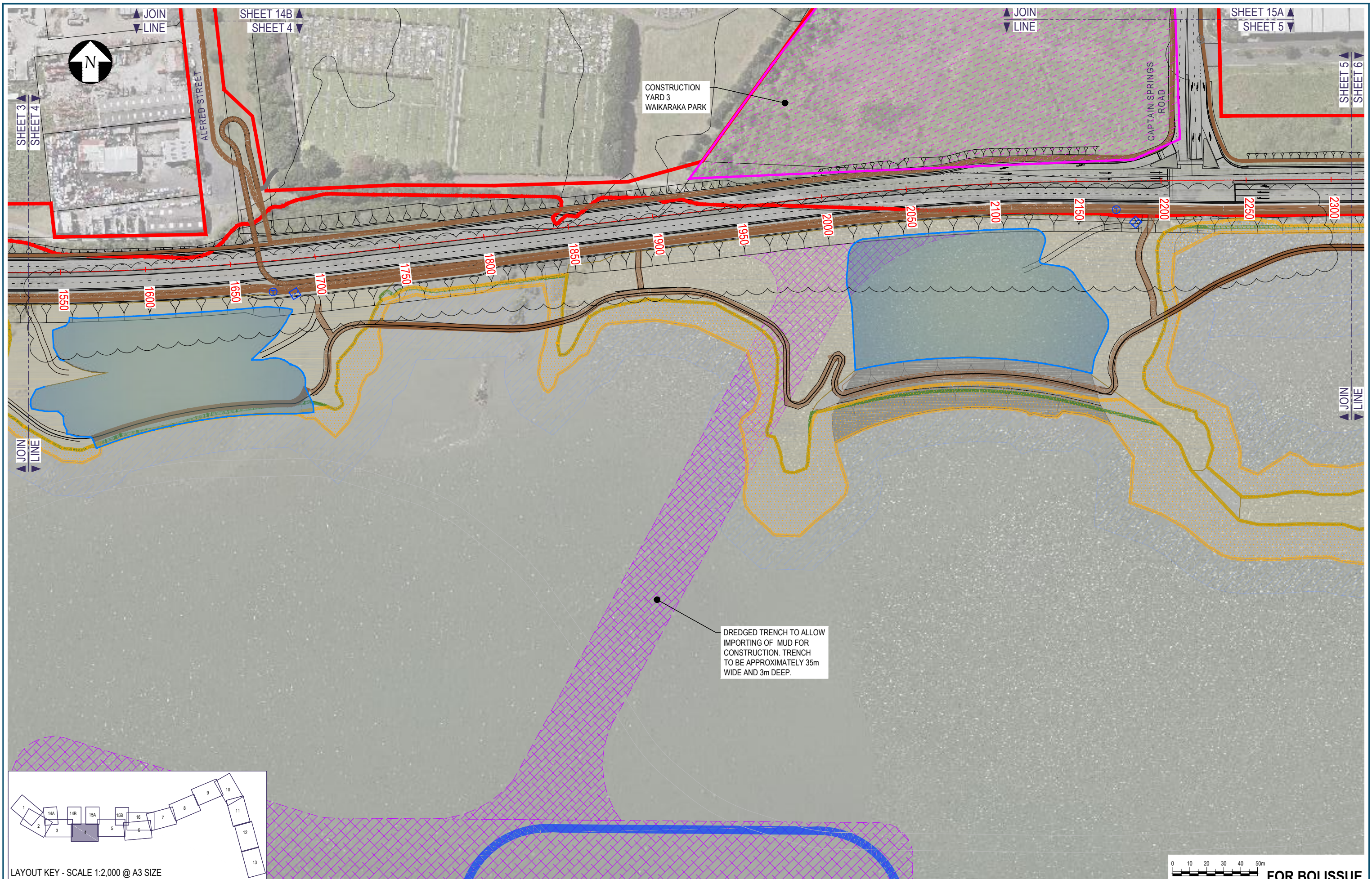

LAYOUT KEY - SCALE 1:2,000 @ A3 SIZE



FOR BOI ISSUE

No.	Issued Status	Drawn	Check'd	App'd	Date
1	BOARD OF INQUIRY	RT	NN	JC	27.06.2017
0	ISSUED FOR CONSENT	AR	NN*	PK*	01.12.2016

DISCLAIMER
 This drawing is for the purpose of supporting applications under the RMA for resource consents and designations. All information shown is subject to final design. Areas and measurements are subject to survey. Where the designs conflict with conditions the conditions will prevail. This Drawing **must not** be used for construction

Drawn A RAM	Drafting Check J MURAHIDY	Reviewed Design Manager N NANCEKIVELL	Approved Alliance Manager J CALDWELL
Designed L COLLINS	Design Check J MURAHIDY	27.06.17	27.06.17
Scale: Original Scale (A1)	Reduced Scale (A3)	AS SHOWN	Contract No PA4014

Drawing Title CONSTRUCTION ACTIVITIES EMBANKMENT SHEET 04	Drawing Number AEE-CA-104	Rev No. 1
---	-------------------------------------	---------------------

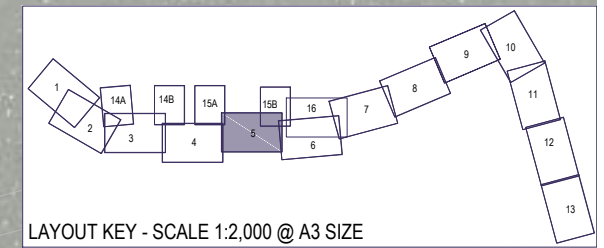

FOR BOI ISSUE

No.	Issued Status	Drawn	Check'd	App'd	Date
1	BOARD OF INQUIRY	RT	NN	JC	27.06.2017
0	ISSUED FOR CONSENT	AR	NN*	PK*	01.12.2016

DISCLAIMER
 This drawing is for the purpose of supporting applications under the RMA for resource consents and designations. All information shown is subject to final design. Areas and measurements are subject to survey. Where the designs conflict with conditions the conditions will prevail. This Drawing **must not** be used for construction

Drawn A RAM	Drafting Check J MURAHIDY	Reviewed Design Manager N NANCEKIVELL 27.06.17	Approved Alliance Manager J CALDWELL 27.06.17
Designed L COLLINS	Design Check J MURAHIDY	Contract No PA4014	
Scale: Original Scale (A1)	Reduced Scale (A3)	AS SHOWN	

Drawing Title CONSTRUCTION ACTIVITES EMBANKMENT SHEET 05	Drawing Number AEE-CA-105	Rev No. 1
--	-------------------------------------	---------------------

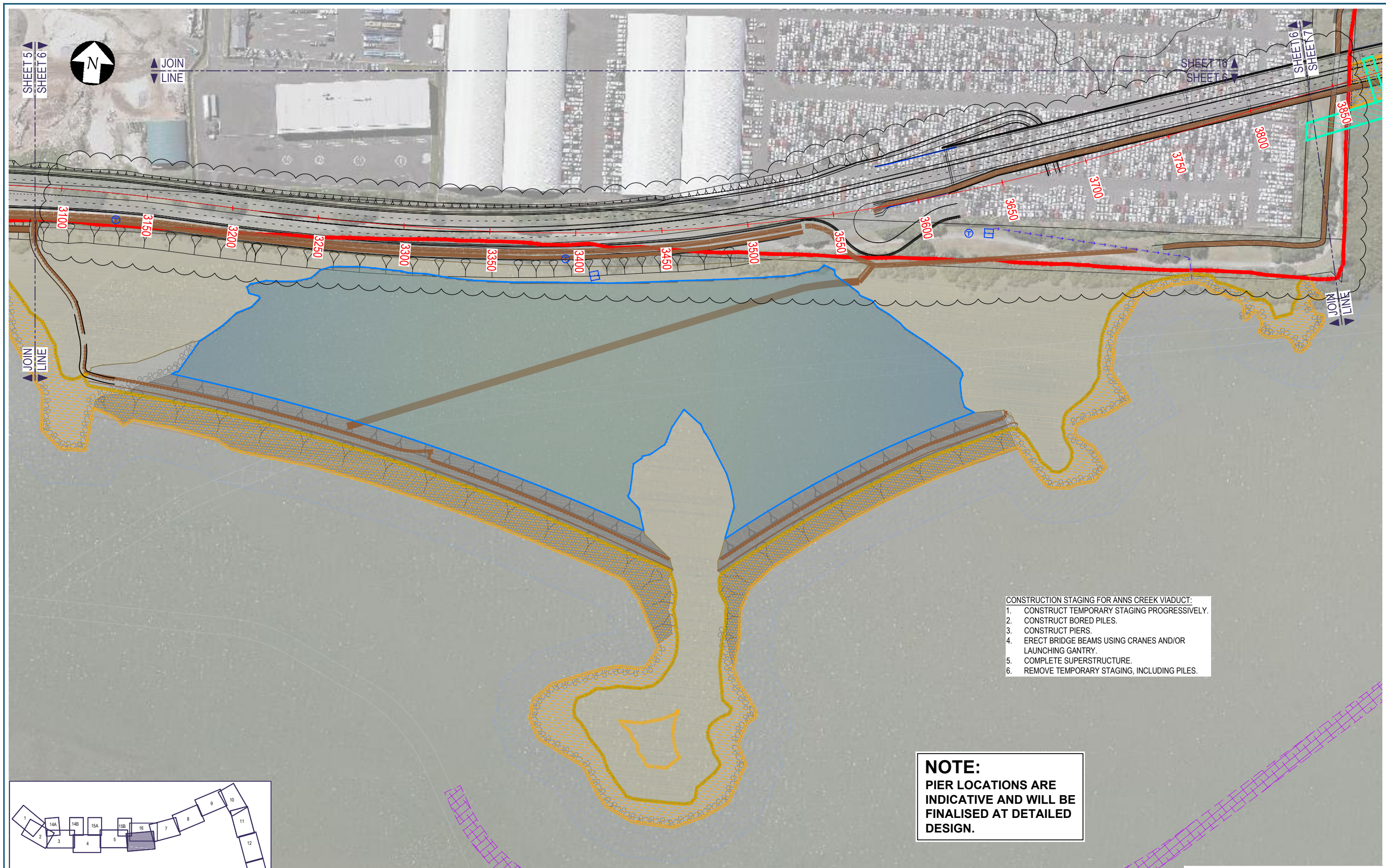

- CONSTRUCTION STAGING FOR ANNS CREEK VIADUCT:
1. CONSTRUCT TEMPORARY STAGING PROGRESSIVELY.
 2. CONSTRUCT BORED PILES.
 3. CONSTRUCT PIERS.
 4. ERECT BRIDGE BEAMS USING CRANES AND/OR LAUNCHING GANTRY.
 5. COMPLETE SUPERSTRUCTURE.
 6. REMOVE TEMPORARY STAGING, INCLUDING PILES.

NOTE:
PIER LOCATIONS ARE INDICATIVE AND WILL BE FINALISED AT DETAILED DESIGN.

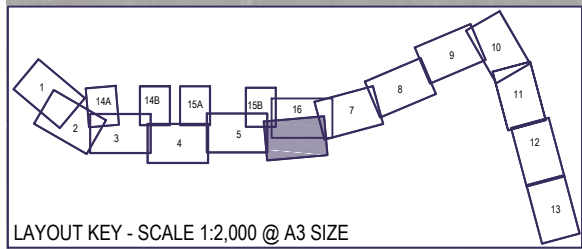

0 10 20 30 40 50m
SCALE 1:2,000 @ A3 SIZE **FOR BOI ISSUE**

No.	Issued Status	Drawn	Check'd	App'd	Date
1	BOARD OF INQUIRY	RT	NN	JC	27.06.2017
0	ISSUED FOR CONSENT	AR	NN*	PK*	01.12.2016

DISCLAIMER
This drawing is for the purpose of supporting applications under the RMA for resource consents and designations. All information shown is subject to final design. Areas and measurements are subject to survey. Where the designs conflict with conditions the conditions will prevail. This Drawing **must not** be used for construction

Drawn A RAM	Drafting Check J MURAHIDY	Reviewed Design Manager N NANCEKIVELL	Approved Alliance Manager J CALDWELL
Designed L COLLINS	Design Check J MURAHIDY	27.06.17	27.06.17
Scale: Original Scale (A1)	Reduced Scale (A3)	AS SHOWN	Contract No PA4014

Drawing Title CONSTRUCTION ACTIVITIES ANNS CREEK/ ANNS CREEK SHEET 06	Drawing Number AEE-CA-106	Rev No. 1
---	-------------------------------------	---------------------



- CONSTRUCTION STAGING FOR ANNS CREEK VIADUCT:
1. CONSTRUCT TEMPORARY STAGING PROGRESSIVELY.
 2. CONSTRUCT BORED PILES.
 3. CONSTRUCT PIERS.
 4. ERECT BRIDGE BEAMS USING CRANES AND/OR LAUNCHING GANTRY.
 5. COMPLETE SUPERSTRUCTURE.
 6. REMOVE TEMPORARY STAGING, INCLUDING PILES.

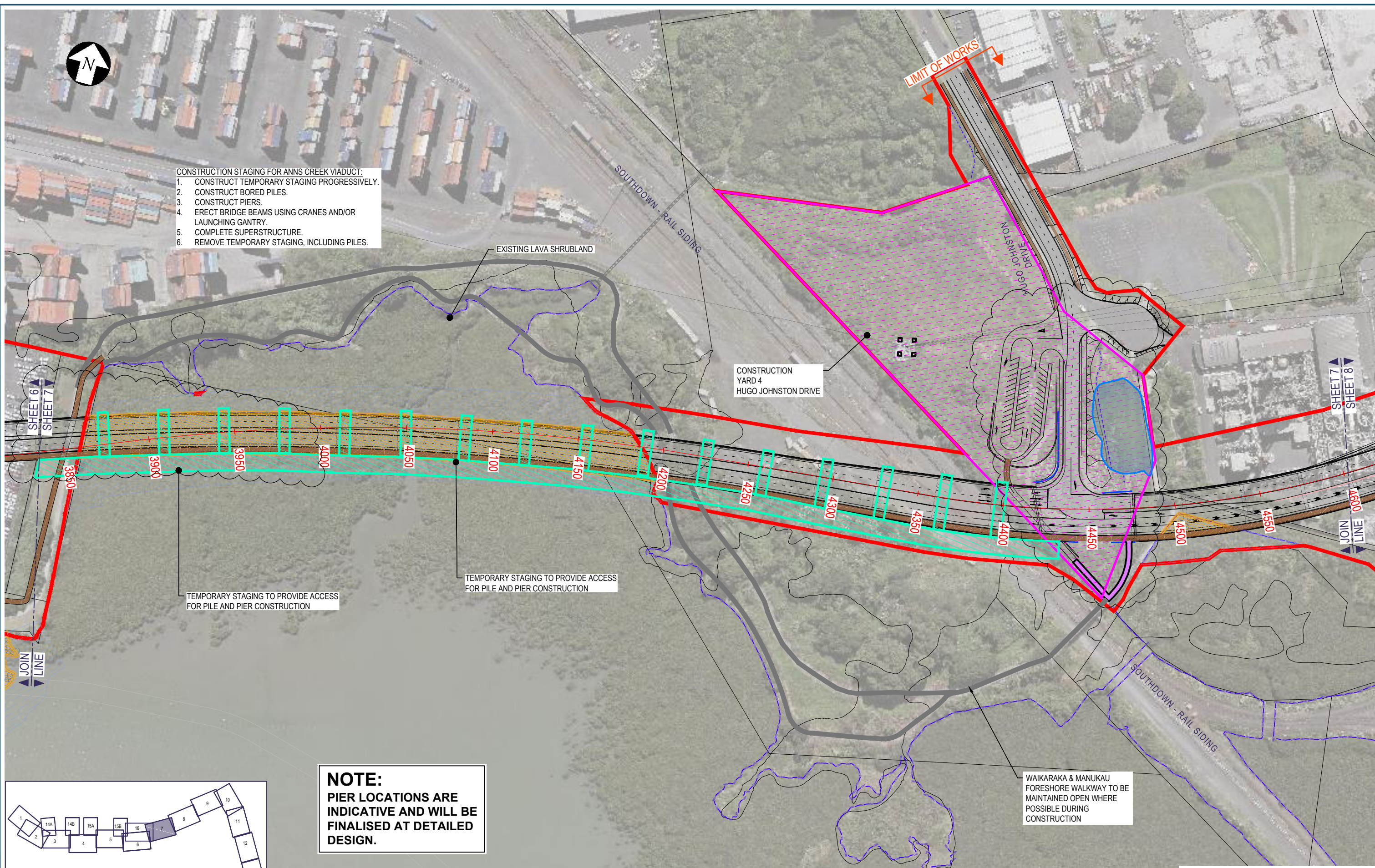

EXISTING LAVA SHRUBLAND

CONSTRUCTION YARD 4
HUGO JOHNSTON DRIVE

TEMPORARY STAGING TO PROVIDE ACCESS FOR PILE AND PIER CONSTRUCTION

TEMPORARY STAGING TO PROVIDE ACCESS FOR PILE AND PIER CONSTRUCTION

WAIKARAKA & MANUKAU FORESHORE WALKWAY TO BE MAINTAINED OPEN WHERE POSSIBLE DURING CONSTRUCTION

NOTE:
PIER LOCATIONS ARE INDICATIVE AND WILL BE FINALISED AT DETAILED DESIGN.

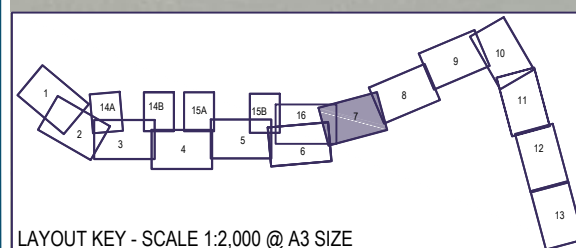

LAYOUT KEY - SCALE 1:2,000 @ A3 SIZE

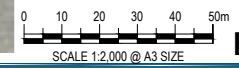

FOR BOI ISSUE

No.	Issued Status	Drawn	Check'd	App'd	Date
2	BOARD OF INQUIRY	RT	NN	JC	27.06.2017
1	ISSUED FOR CONSENT - GSR GRADE SEPARATION	RT	NN*	PK*	14.12.2016
0	ISSUED FOR CONSENT	AR	NN*	PK*	01.12.2016

DISCLAIMER
This drawing is for the purpose of supporting applications under the RMA for resource consents and designations. All information shown is subject to final design. Areas and measurements are subject to survey. Where the designs conflict with conditions the conditions will prevail. This Drawing **must not** be used for construction



Drawn	A RAM	Drafting Check	J MURAHIDY	Reviewed Design Manager	N NANCEKIVELL	Approved Alliance Manager	J CALDWELL
Designed	L COLLINS	Design Check	J MURAHIDY		27.06.17		27.06.17
Scale:	Original Scale (A1)	Reduced Scale (A3)	AS SHOWN	Contract No.	PA4014		

Drawing Title	CONSTRUCTION ACTIVITIES		
	ANNS CREEK SHEET 07		
Drawing Number	AEE-CA-107		
Rev No.	2		

- CONSTRUCTION STAGING FOR ANNS CREEK VIADUCT:**
1. CONSTRUCT TEMPORARY STAGING PROGRESSIVELY.
 2. CONSTRUCT BORED PILES.
 3. CONSTRUCT PIERS.
 4. ERECT BRIDGE BEAMS USING CRANES AND/OR LAUNCHING GANTRY.
 5. COMPLETE SUPERSTRUCTURE.
 6. REMOVE TEMPORARY STAGING, INCLUDING PILES.

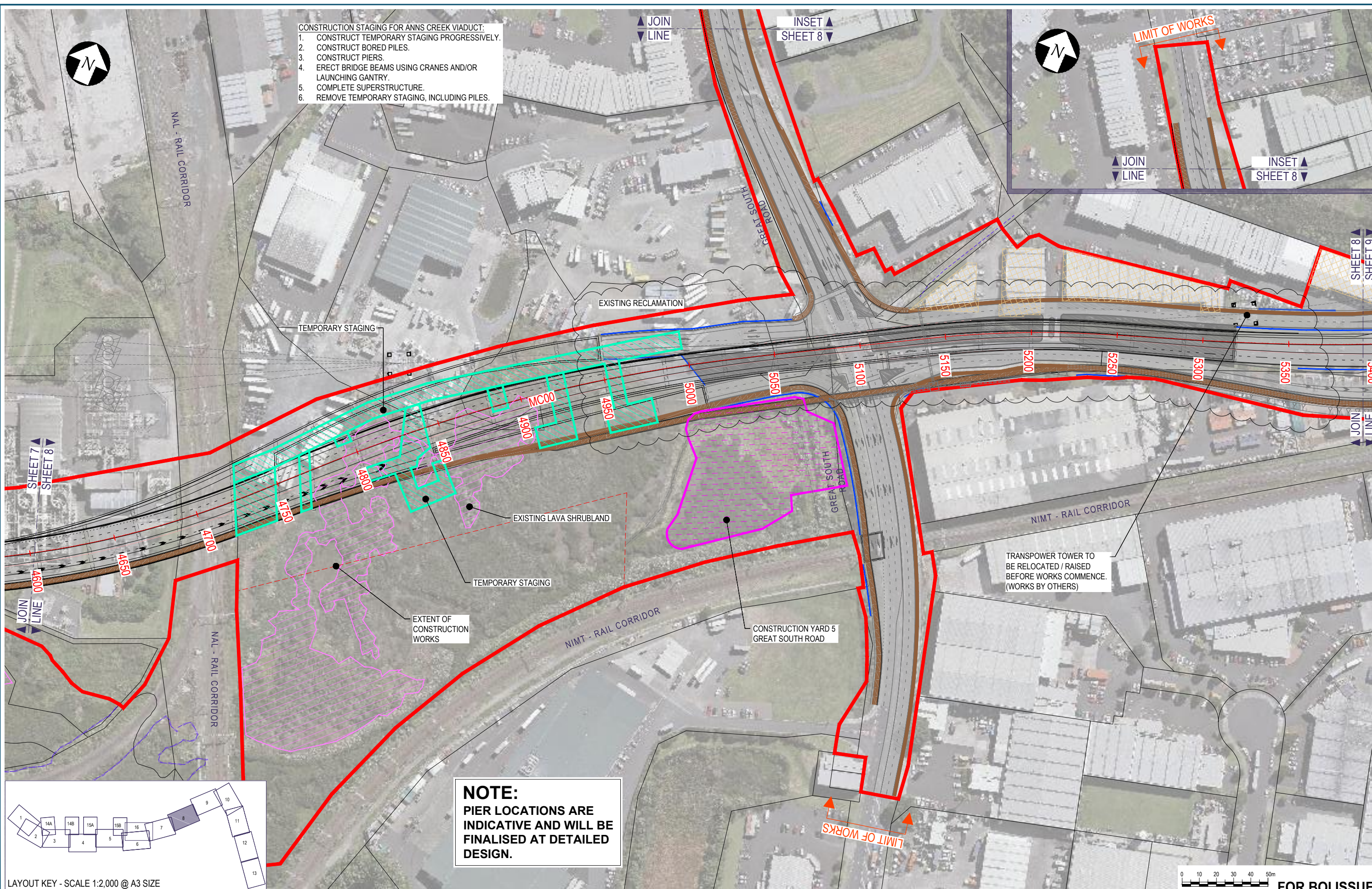

NOTE:
PIER LOCATIONS ARE INDICATIVE AND WILL BE FINALISED AT DETAILED DESIGN.

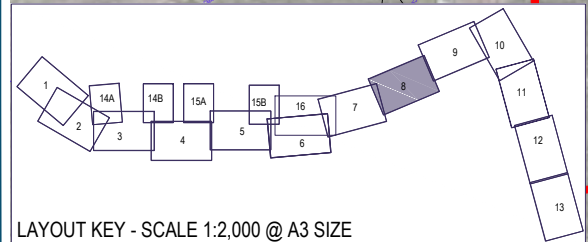

LAYOUT KEY - SCALE 1:2,000 @ A3 SIZE

SCALE 1:2,000 @ A3 SIZE **FOR BOI ISSUE**

No.	Issued Status	Drawn	Check'd	App'd	Date
2	BOARD OF INQUIRY	RT	NN	JC	27.06.2017
1	ISSUED FOR CONSENT - GSR GRADE SEPARATION	RT	NN*	PK*	14.12.2016
0	ISSUED FOR CONSENT	AR	NN*	PK*	01.12.2016

DISCLAIMER
This drawing is for the purpose of supporting applications under the RMA for resource consents and designations. All information shown is subject to final design. Areas and measurements are subject to survey. Where the designs conflict with conditions the conditions will prevail. This Drawing **must not** be used for construction

Drawn	A RAM	Drafting Check	J MURAHIDY	Reviewed Design Manager	N NANCEKIVELL	Approved Alliance Manager	J CALDWELL
Designed	L COLLINS	Design Check	J MURAHIDY		27.06.17		27.06.17
Scale:	Original Scale (A1)	Reduced Scale (A3)	AS SHOWN	Contract No	PA4014		

Drawing Title	CONSTRUCTION ACTIVITIES ANNS CREEK/ SYLVIA PARK ROAD SHEET 08		
Drawing Number	AEE-CA-108	Rev No.	2

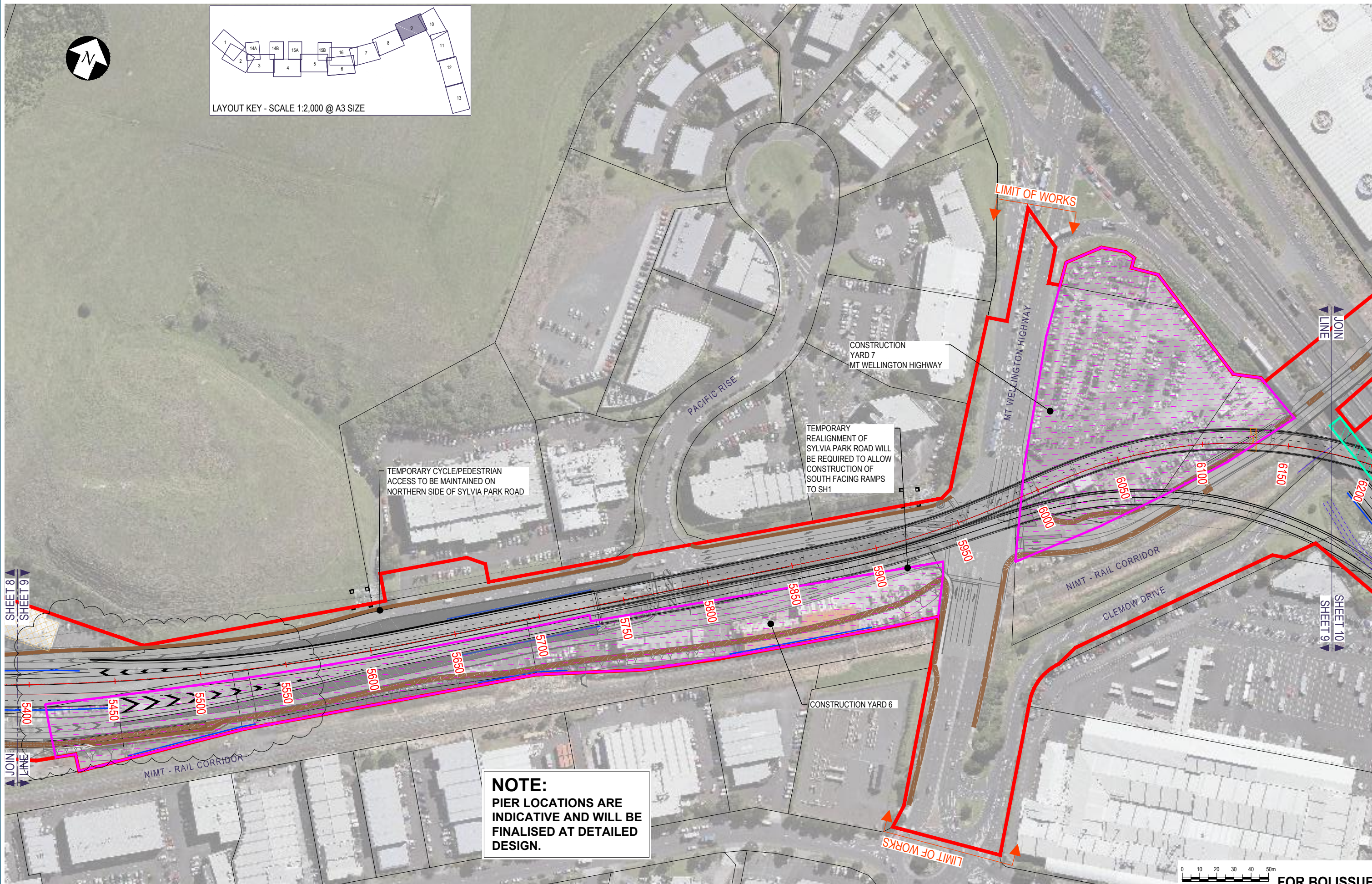
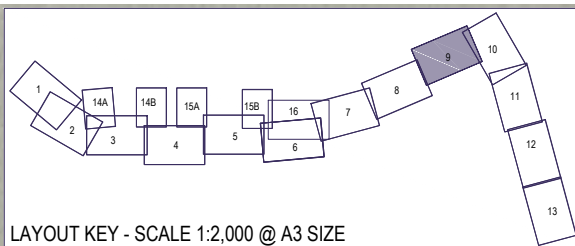

TEMPORARY CYCLE/PEDESTRIAN ACCESS TO BE MAINTAINED ON NORTHERN SIDE OF SYLVIA PARK ROAD

TEMPORARY REALIGNMENT OF SYLVIA PARK ROAD WILL BE REQUIRED TO ALLOW CONSTRUCTION OF SOUTH FACING RAMP TO SH1

NOTE:
PIER LOCATIONS ARE INDICATIVE AND WILL BE FINALISED AT DETAILED DESIGN.

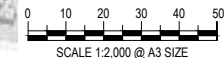

FOR BOI ISSUE

No.	Issued Status	Drawn	Check'd	App'd	Date
2	BOARD OF INQUIRY	RT	NN	JC	27.06.2017
1	ISSUED FOR CONSENT - GSR GRADE SEPARATION	RT	NN*	PK*	14.12.2016
0	ISSUED FOR CONSENT	AR	NN*	PK*	01.12.2016

DISCLAIMER
This drawing is for the purpose of supporting applications under the RMA for resource consents and designations. All information shown is subject to final design. Areas and measurements are subject to survey. Where the designs conflict with conditions the conditions will prevail. This Drawing **must not** be used for construction

Drawn A RAM	Drafting Check J MURAHIDY	Reviewed Design Manager N NANCEKIVELL	Approved Alliance Manager J CALDWELL
Designed L COLLINS	Design Check J MURAHIDY	27.06.17	27.06.17
Scale: Original Scale (A1)	Reduced Scale (A3)	AS SHOWN	Contract No PA4014

Drawing Title CONSTRUCTION ACTIVITIES ANNS CREEK/ SYLVIA PARK ROAD SHEET 09	Drawing Number AEE-CA-109	Rev No. 2
---	-------------------------------------	---------------------

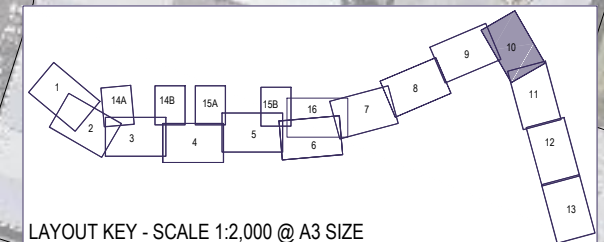

LAYOUT KEY - SCALE 1:2,000 @ A3 SIZE

NOTE:
PIER LOCATIONS ARE
INDICATIVE AND WILL BE
FINALISED AT DETAILED
DESIGN.

STATE HIGHWAY 1 SOUTHBOUND ON RAMP STRUCTURE:
STAGE 1:
ESTABLISH AREAS ADJACENT TO A,B AND C (THIS WILL
REQUIRE REDUCING LANE WIDTHS). ERECT TEMPORARY
PIER SUPPORTS.
STAGE 2:
DURING NIGHT MOTORWAY CLOSURE, STEEL BEAMS TO
BE LIFTED INTO POSITION.
STAGE 3:
REMOVE TEMPORARY PIER SUPPORTS.

CONSTRUCTION
YARD 8

SHEET 10
SHEET 11

TRANSPOWER TOWER TO
BE RELOCATED / RAISED
BEFORE WORKS
COMMENCE.
(WORKS BY OTHERS)

TRANSPOWER TOWER TO
BE REPLACED WITH MONO-POLE
BEFORE WORKS COMMENCE.
(WORKS BY OTHERS)

JOIN
LINE

SHEET 10
SHEET 9

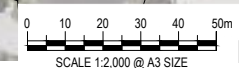

FOR BOI ISSUE

No.	Issued Status	Drawn	Check'd	App'd	Date
1	BOARD OF INQUIRY	RT	NN	JC	27.06.2017
0	ISSUED FOR CONSENT	AR	NN*	PK*	01.12.2016

DISCLAIMER
This drawing is for the purpose of supporting applications under the RMA for resource consents and designations. All information shown is subject to final design. Areas and measurements are subject to survey. Where the designs conflict with conditions the conditions will prevail. This Drawing **must not** be used for construction

NZ TRANSPORT AGENCY
UWA CA KOTAH

East West Link

Drawn	A RAM	Drafting Check	J MURAHIDY	Reviewed	N NANCEKIVELL	Approved	J CALDWELL
Designed	L COLLINS	Design Check	J MURAHIDY	Design Manager	27.06.17	Alliance Manager	27.06.17
Scale:	Original Scale (A1)	Reduced Scale (A3)	AS SHOWN	Contract No		PA4014	

Drawing Title	CONSTRUCTION ACTIVITIES SH1/ SYLVIA PARK RAMPS SHEET 10		
Drawing Number	AEE-CA-110		
Rev No.	1		

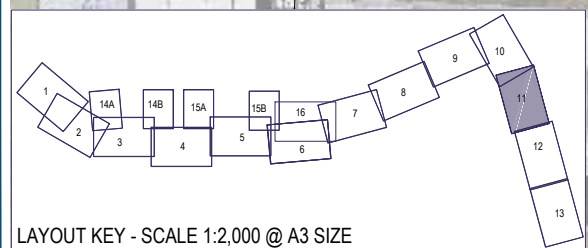
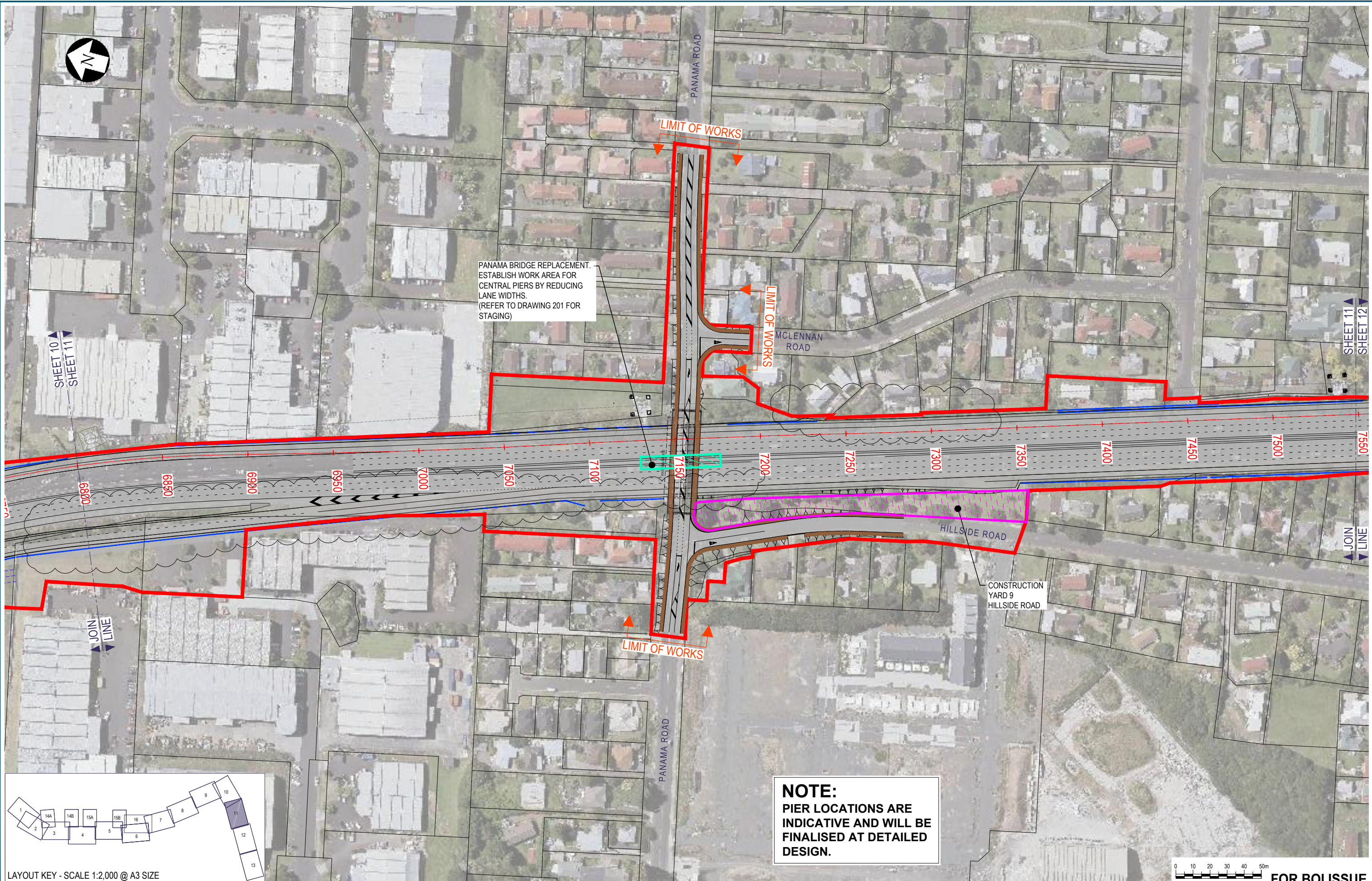

No.	Issued Status	Drawn	Check'd	App'd	Date
1	BOARD OF INQUIRY	RT	NN	JC	27.06.2017
0	ISSUED FOR CONSENT	AR	NN*	PK*	01.12.2016

DISCLAIMER
 This drawing is for the purpose of supporting applications under the RMA for resource consents and designations. All information shown is subject to final design. Areas and measurements are subject to survey. Where the designs conflict with conditions the conditions will prevail. This Drawing **must not** be used for construction



Drawn	A RAM	Drafting Check	J MURAHIDY	Reviewed	N NANCEKIVELL	Approved	J CALDWELL
Designed	L COLLINS	Design Check	J MURAHIDY		27.06.17		27.06.17
Scale:	Original Scale (A1)	Reduced Scale (A3)	AS SHOWN	Contract No		PA4014	

Drawing Title	CONSTRUCTION ACTIVITIES SH1/ PANAMA ROAD SHEET 11		
Drawing Number	AEE-CA-111	Rev No.	1

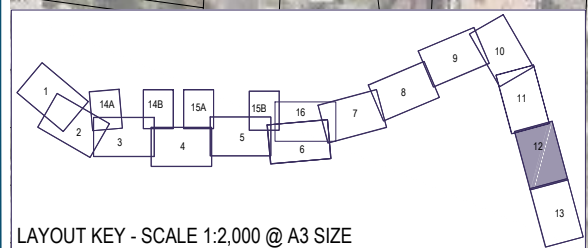
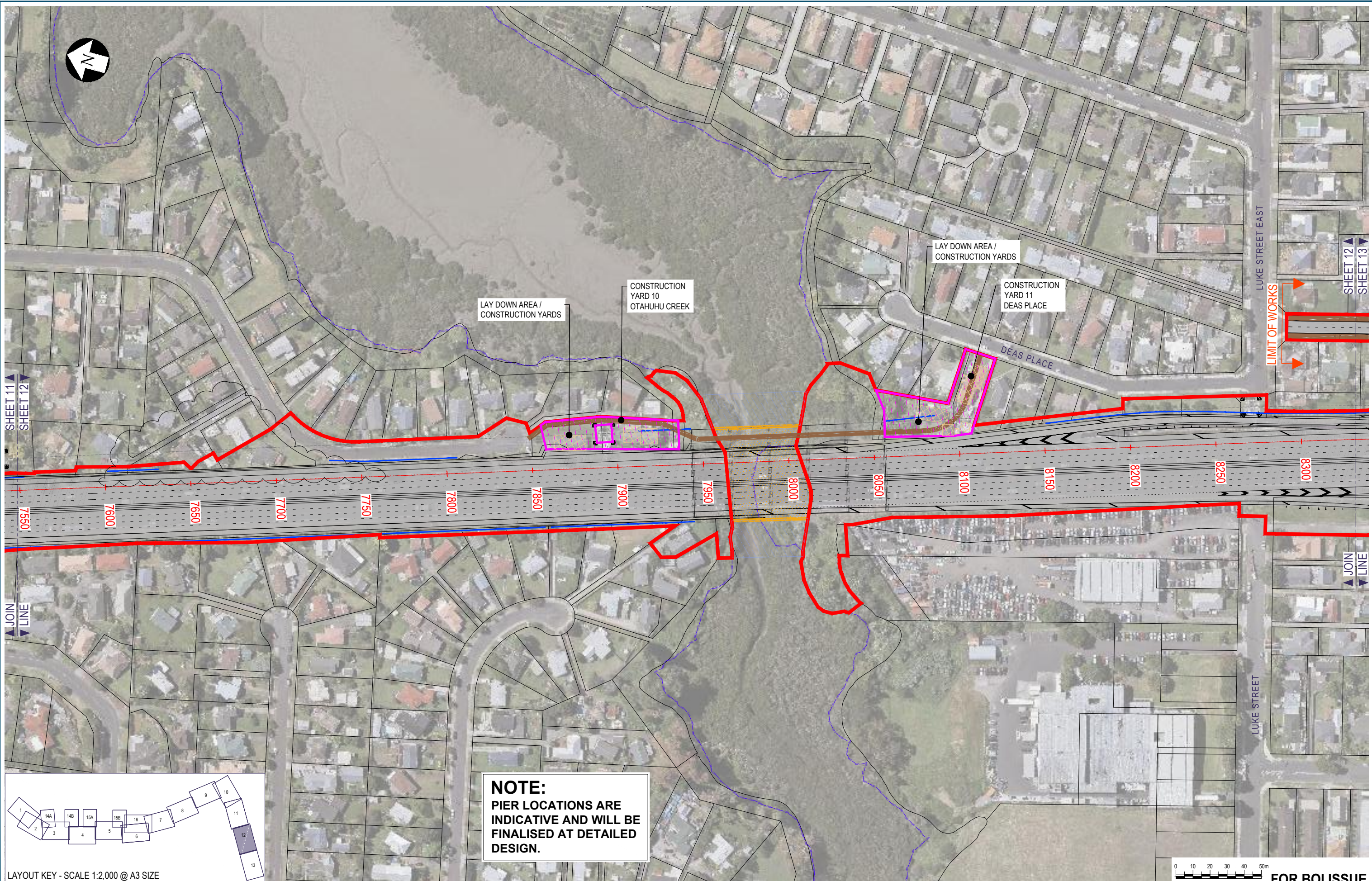

NOTE:
PIER LOCATIONS ARE
INDICATIVE AND WILL BE
FINALISED AT DETAILED
DESIGN.

No.	Issued Status	Drawn	Check'd	App'd	Date
1	BOARD OF INQUIRY	RT	NN	JC	27.06.2017
0	ISSUED FOR CONSENT	AR	NN*	PK*	01.12.2016

DISCLAIMER
This drawing is for the purpose of supporting applications under the RMA for resource consents and designations. All information shown is subject to final design. Areas and measurements are subject to survey. Where the designs conflict with conditions the conditions will prevail. This Drawing **must not** be used for construction

Drawn A RAM	Drafting Check J MURAHIDY	Reviewed Design Manager N NANCEKIVELL	Approved Alliance Manager J CALDWELL
Designed L COLLINS	Design Check J MURAHIDY	27.06.17	27.06.17
Scale: Original Scale (A1)	Reduced Scale (A3)	AS SHOWN	Contract No PA4014

Drawing Title CONSTRUCTION ACTIVITIES SH1/ OTAHUHU CREEK SHEET 12	Drawing Number AEE-CA-112	Rev No. 1
--	------------------------------	--------------

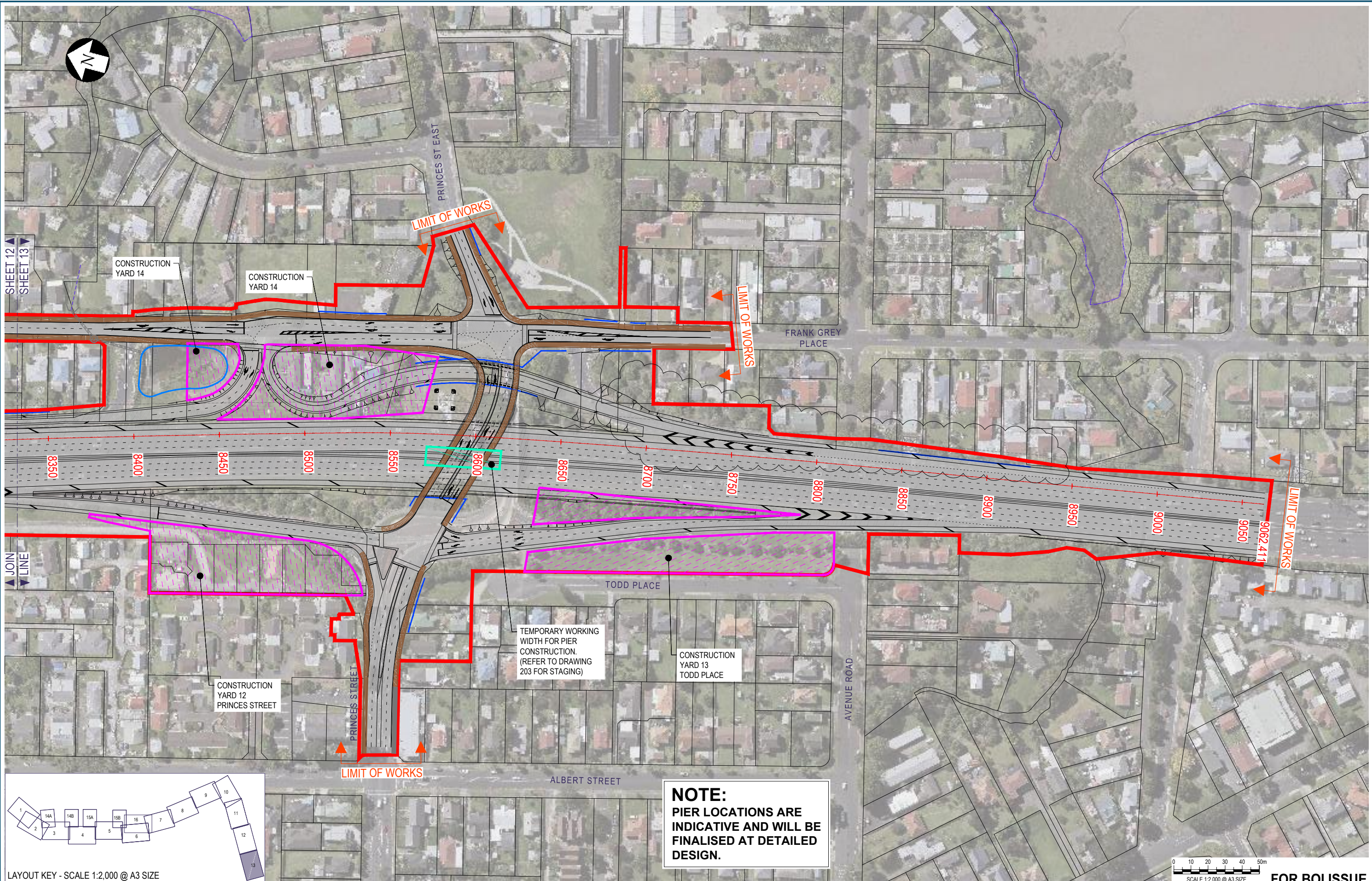

SHEET 12
SHEET 13

JOIN
LINE

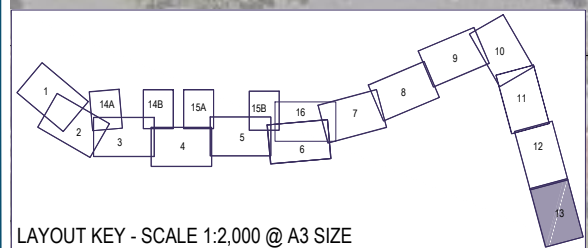

NOTE:
PIER LOCATIONS ARE
INDICATIVE AND WILL BE
FINALISED AT DETAILED
DESIGN.

No.	Issued Status	Drawn	Check'd	App'd	Date
1	BOARD OF INQUIRY	RT	NN	JC	27.06.2017
0	ISSUED FOR CONSENT	AR	NN*	PK*	01.12.2016

DISCLAIMER
This drawing is for the purpose of supporting applications under the RMA for resource consents and designations. All information shown is subject to final design. Areas and measurements are subject to survey. Where the designs conflict with conditions the conditions will prevail. This Drawing **must not** be used for construction

Drawn A RAM	Drafting Check J MURAHIDY	Reviewed Design Manager N NANCEKIVELL	Approved Alliance Manager J CALDWELL
Designed L COLLINS	Design Check J MURAHIDY	27.06.17	27.06.17
Scale: Original Scale (A1)	Reduced Scale (A3)	AS SHOWN	Contract No PA4014

Drawing Title CONSTRUCTION ACTIVITIES PRINCES ST INTERCHAGNE SHEET 13	Drawing Number AEE-CA-113	Rev No. 1
--	------------------------------	--------------

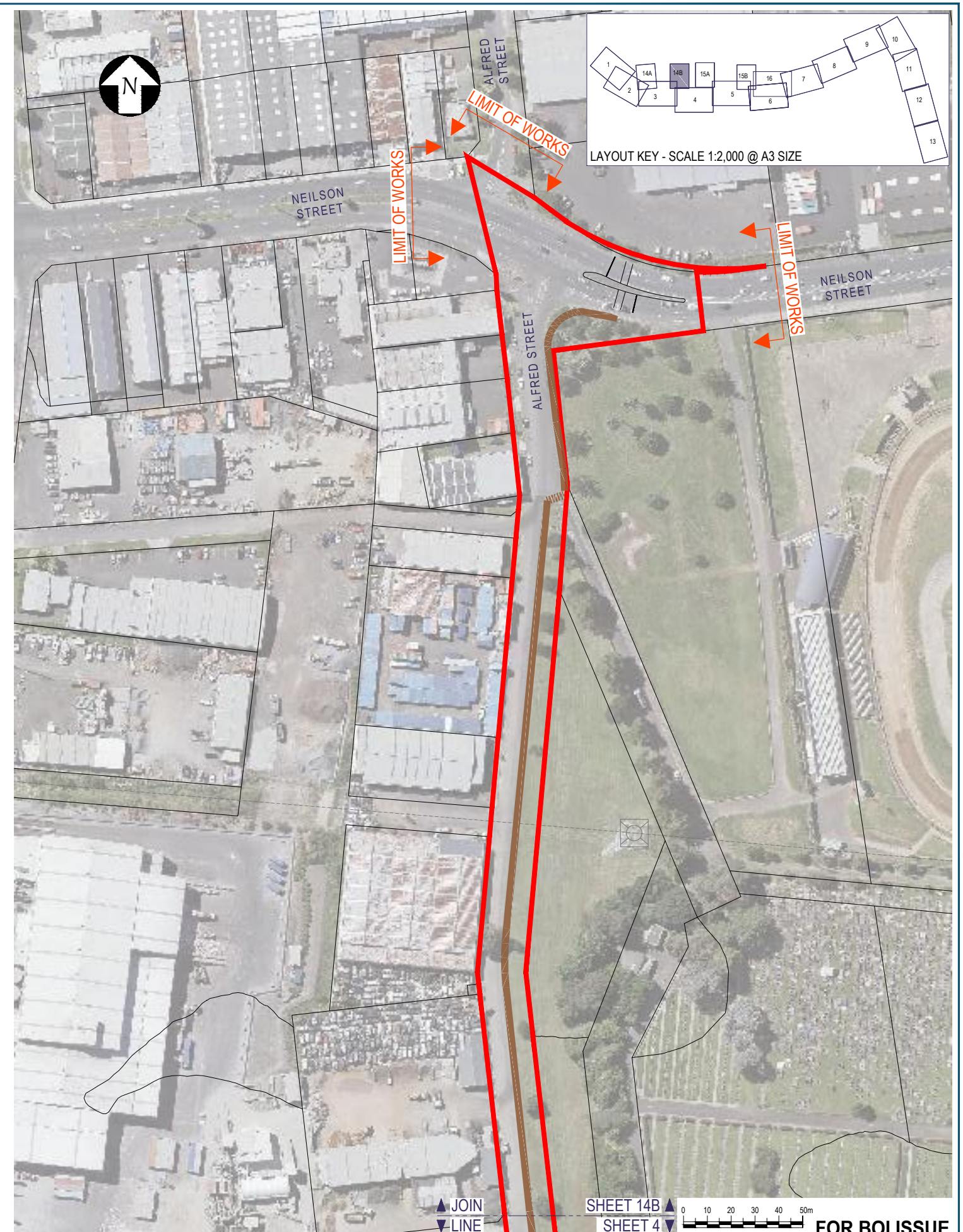
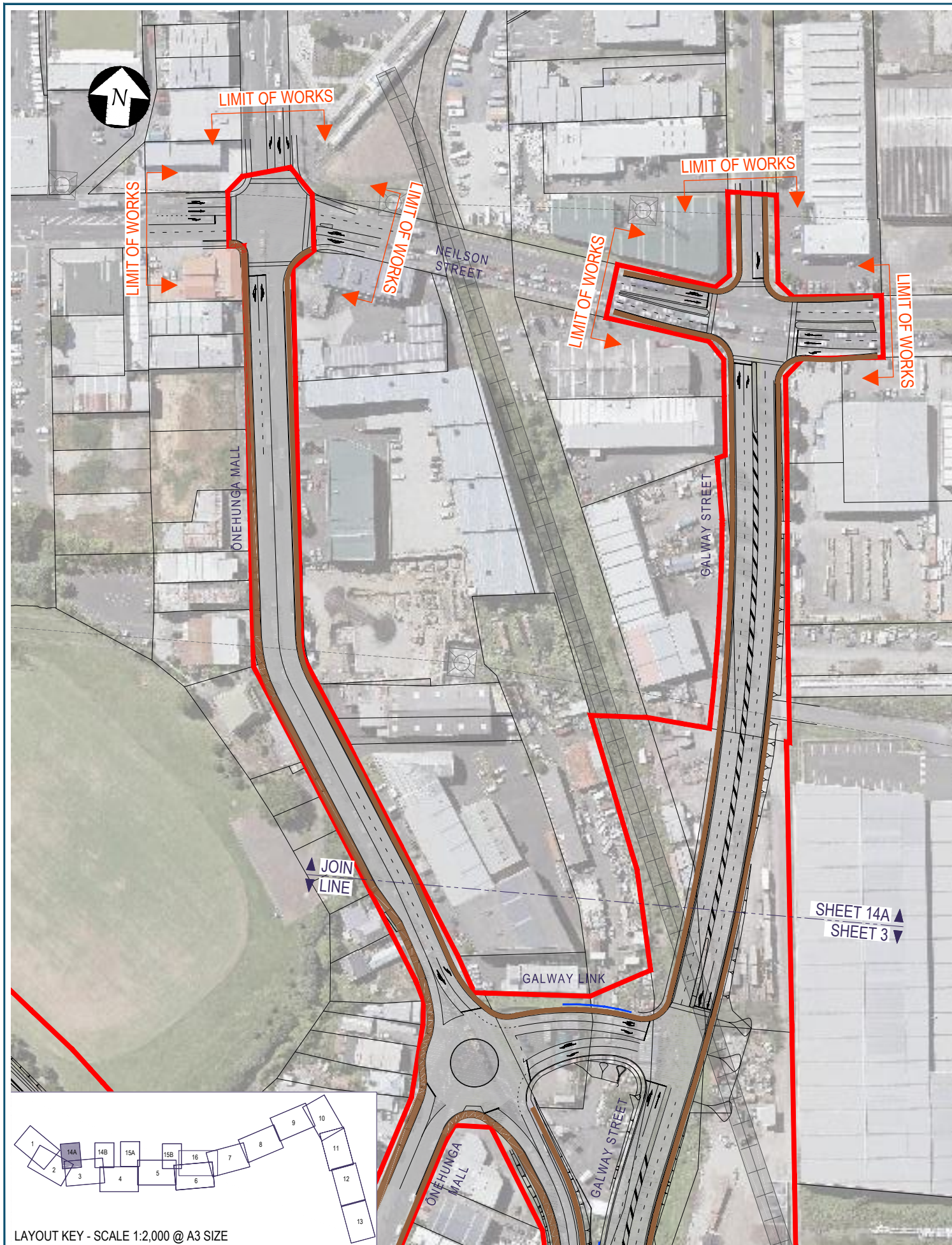

LAYOUT KEY - SCALE 1:2,000 @ A3 SIZE

LAYOUT KEY - SCALE 1:2,000 @ A3 SIZE

No.	Issued Status	Drawn	Check'd	App'd	Date
1	BOARD OF INQUIRY	RT	NN	JC	27.06.2017
0	ISSUED FOR CONSENT	AR	NN*	PK*	01.12.2016

DISCLAIMER
 This drawing is for the purpose of supporting applications under the RMA for resource consents and designations. All information shown is subject to final design. Areas and measurements are subject to survey. Where the designs conflict with conditions the conditions will prevail. This Drawing **must not** be used for construction

Drawn A RAM	Drafting Check J MURAHIDY	Reviewed Design Manager N NANCEKIVELL	Approved Alliance Manager J CALDWELL
Designed L COLLINS	Design Check J MURAHIDY	27.06.17	27.06.17
Scale: Original Scale (A1)	Reduced Scale (A3)	AS SHOWN	Contract No PA4014

Drawing Title CONSTRUCTION ACTIVITIES NEILSON STREET INTERCHANGE - LOCAL ROADS SHEET 14A & 14B	Drawing Number AEE-CA-114	Rev No. 1
---	------------------------------	--------------



No.	Issued Status	Drawn	Check'd	App'd	Date
1	BOARD OF INQUIRY	RT	NN	JC	27.06.2017
0	ISSUED FOR CONSENT	AR	NN*	PK*	01.12.2016

DISCLAIMER
 This drawing is for the purpose of supporting applications under the RMA for resource consents and designations. All information shown is subject to final design. Areas and measurements are subject to survey. Where the designs conflict with conditions the conditions will prevail. This Drawing **must not** be used for construction.

NZ TRANSPORT AGENCY
 UTA CA WŪTAH

East West Link

Drawn A RAM	Drafting Check J MURAHIDY	Reviewed Design Manager N NANCEKIVELL	Approved Alliance Manager J CALDWELL
Designed L COLLINS	Design Check J MURAHIDY	27.06.17	27.06.17
Scale: Original Scale (A1)	Reduced Scale (A3)	AS SHOWN	Contract No PA4014

Drawing Title CONSTRUCTION ACTIVITIES CAPTAIN SPRINGS ROAD/ PORTS LINK SHEET 15A & 15B	Drawing Number AEE-CA-115	Rev No. 1
--	-------------------------------------	---------------------

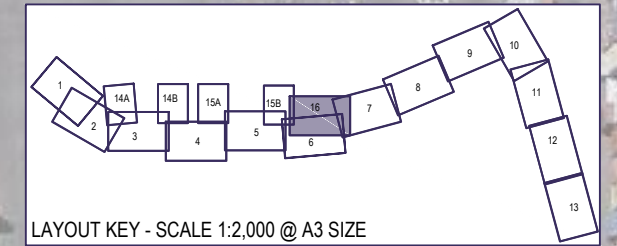

NOTE:
PIER LOCATIONS ARE
INDICATIVE AND WILL BE
FINALISED AT DETAILED
DESIGN.

0 10 20 30 40 50m
SCALE 1:2,000 @ A3 SIZE **FOR BOI ISSUE**

No.	Issued Status	Drawn	Check'd	App'd	Date
1	BOARD OF INQUIRY	RT	NN	JC	27.06.2017
0	ISSUED FOR CONSENT	AR	NN*	PK*	01.12.2016

DISCLAIMER
This drawing is for the purpose of supporting applications under the RMA for resource consents and designations. All information shown is subject to final design. Areas and measurements are subject to survey. Where the designs conflict with conditions the conditions will prevail. This Drawing **must not** be used for construction

Drawn A RAM	Drafting Check J MURAHIDY	Reviewed Design Manager N NANCEKIVELL	Approved Alliance Manager J CALDWELL
Designed L COLLINS	Design Check J MURAHIDY	27.06.17	27.06.17
Scale: Original Scale (A1)	Reduced Scale (A3)	AS SHOWN	Contract No PA4014

Drawing Title CONSTRUCTION ACTIVITIES EMBANKMENT SHEET 16	Drawing Number AEE-CA-116	Rev No. 1
---	-------------------------------------	---------------------

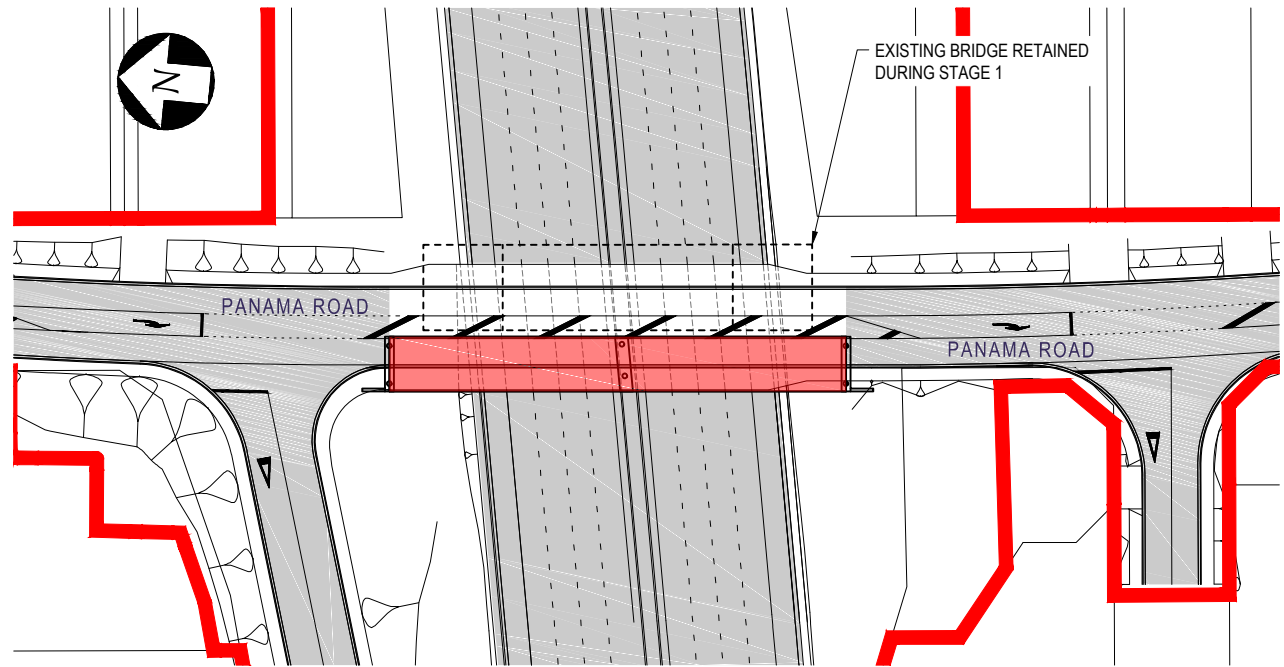

**BRIDGE CONSTRUCTION
STAGE 1
(11.25m OF NEW BRIDGE)**
SCALE 1:2000 @ A3

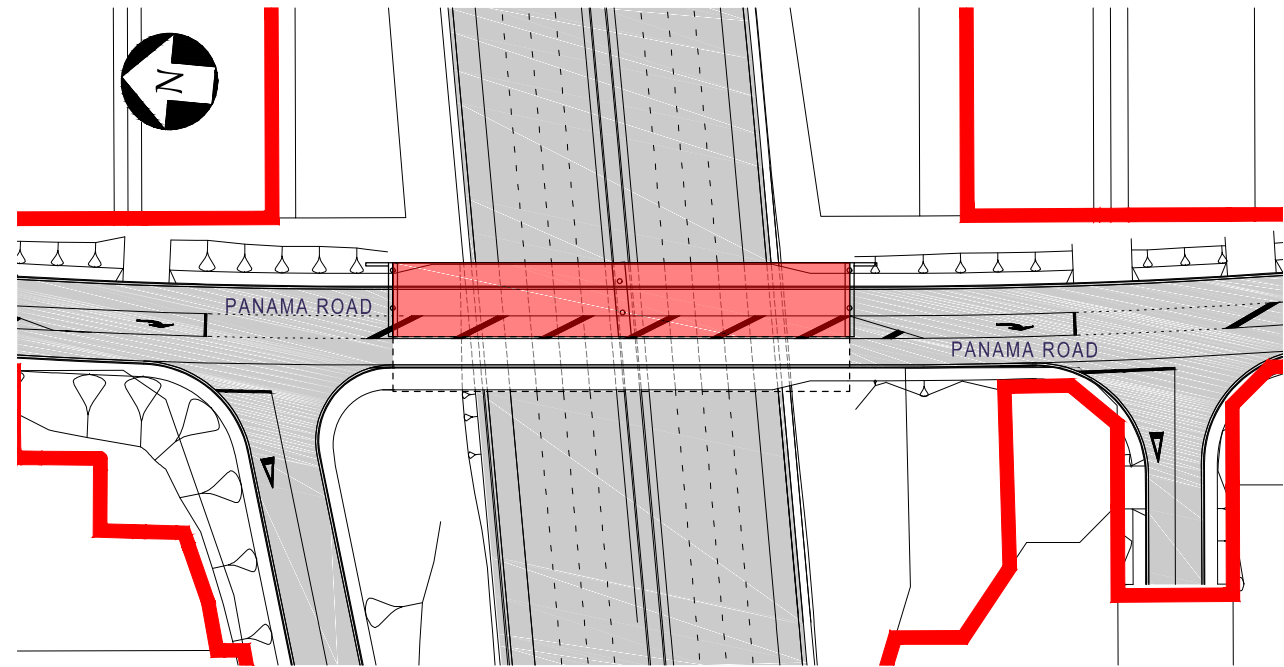

**BRIDGE CONSTRUCTION
STAGE 2
DECONSTRUCT EXISTING, CONSTRUCT REMAINING**
SCALE 1:2000 @ A3

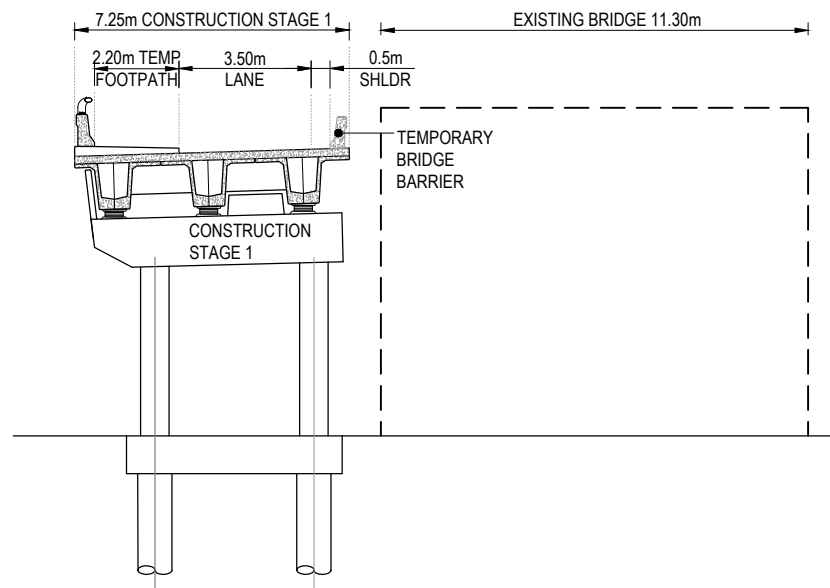

STAGE 1: CONSTRUCT 7.25m OF NEW BRIDGE

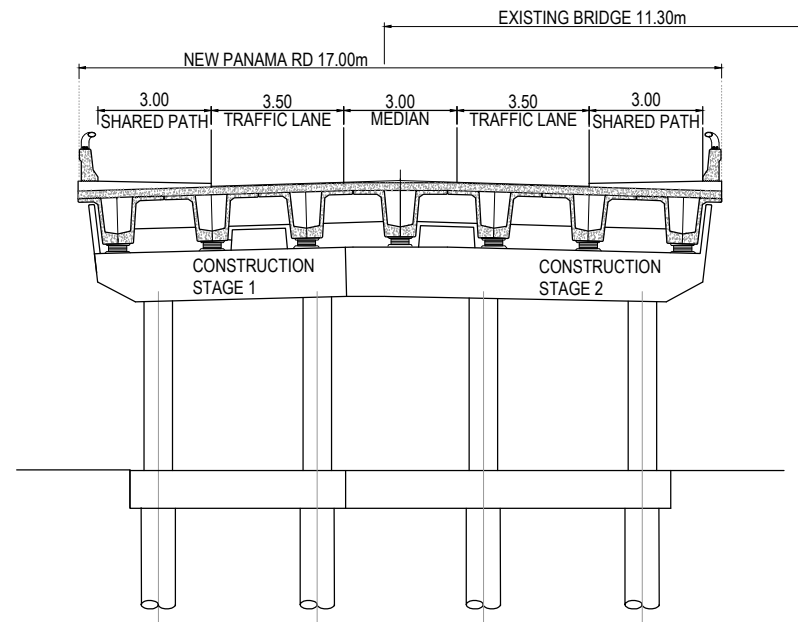

STAGE 2: DECONSTRUCT EXISTING, CONSTRUCT REMAINING

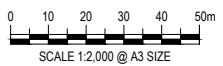

FOR BOI ISSUE

No.	Issued Status	Drawn	Check'd	App'd	Date
1	BOARD OF INQUIRY	RT	NN	JC	27.06.2017
0	ISSUED FOR CONSENT	AR	NN*	PK*	01.12.2016

DISCLAIMER
This drawing is for the purpose of supporting applications under the RMA for resource consents and designations. All information shown is subject to final design. Areas and measurements are subject to survey. Where the designs conflict with conditions the conditions will prevail. This Drawing **must not** be used for construction



Drawn A RAM	Drafting Check J MURAHIDY	Reviewed Design Manager N NANCEKIVELL	Approved Alliance Manager J CALDWELL
Designed L COLLINS	Design Check J MURAHIDY	27.06.17	27.06.17
Scale: Original Scale (A1)	Reduced Scale (A3)	AS SHOWN	Contract No PA4014

Drawing Title CONSTRUCTION ACTIVITIES SH1/ PANAMA ROAD BRIDGE STAGING PLANS	Rev No. 1
Drawing Number AEE-CA-201	

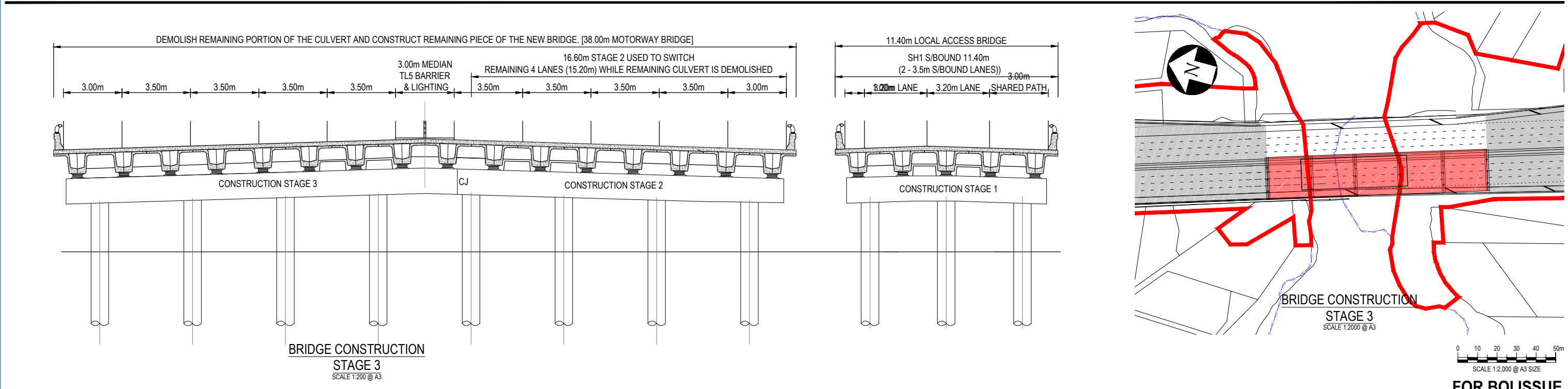
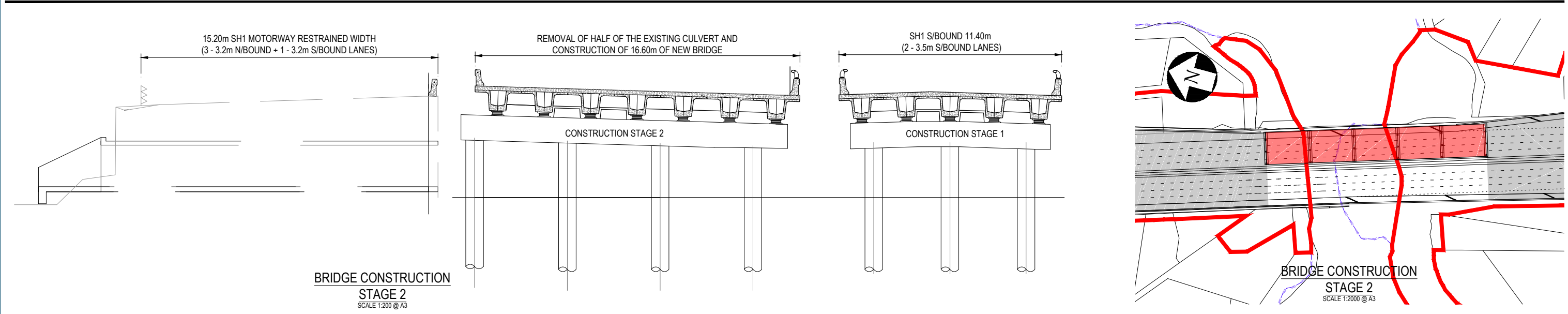
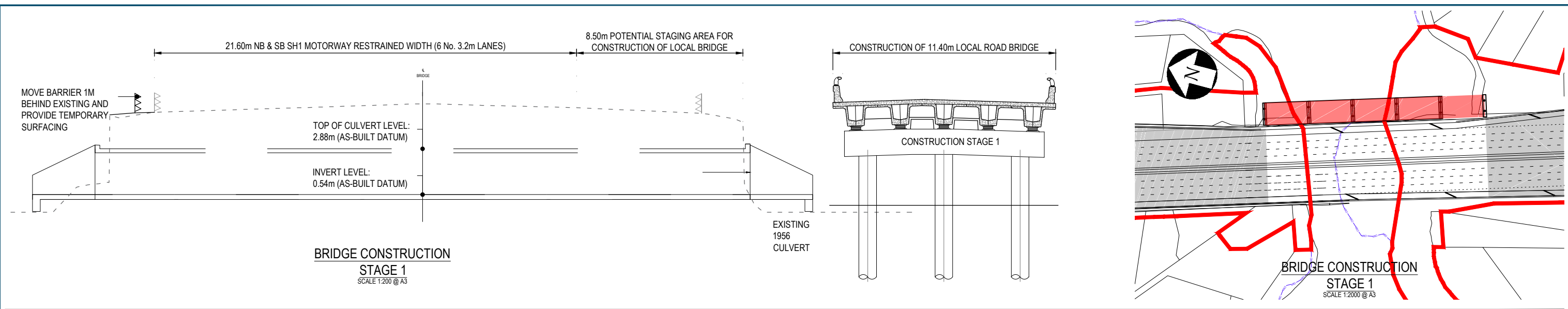

DISCLAIMER This drawing is for the purpose of supporting applications under the RMA for resource consents and designations. All information shown is subject to final design. Areas and measurements are subject to survey. Where the designs conflict with conditions the conditions will prevail. This Drawing must not be used for construction.								Drawn: A RAM Designed: L COLLINS Scale: Original Scale (A1) Reduced Scale (A3) AS SHOWN		Drafting Check: J MURAHIDY Design Check: J MURAHIDY Reviewed Design Manager: N NANCEKIVELL 27.06.17 Approved Alliance Manager: J CALDWELL 27.06.17 Contract No: PA4014		Drawing Title: CONSTRUCTION ACTIVITIES SH1/ OTAHUHU CREEK BRIDGE STAGING PLANS Drawing Number: AEE-CA-202 Rev No: 1	
1 BOARD OF INQUIRY 0 ISSUED FOR CONSENT		RT	NN	JC	27.06.2017	AR	NN*	PK*	01.12.2016				
No.	Issued Status	Drawn	Check'd	App'd	Date								

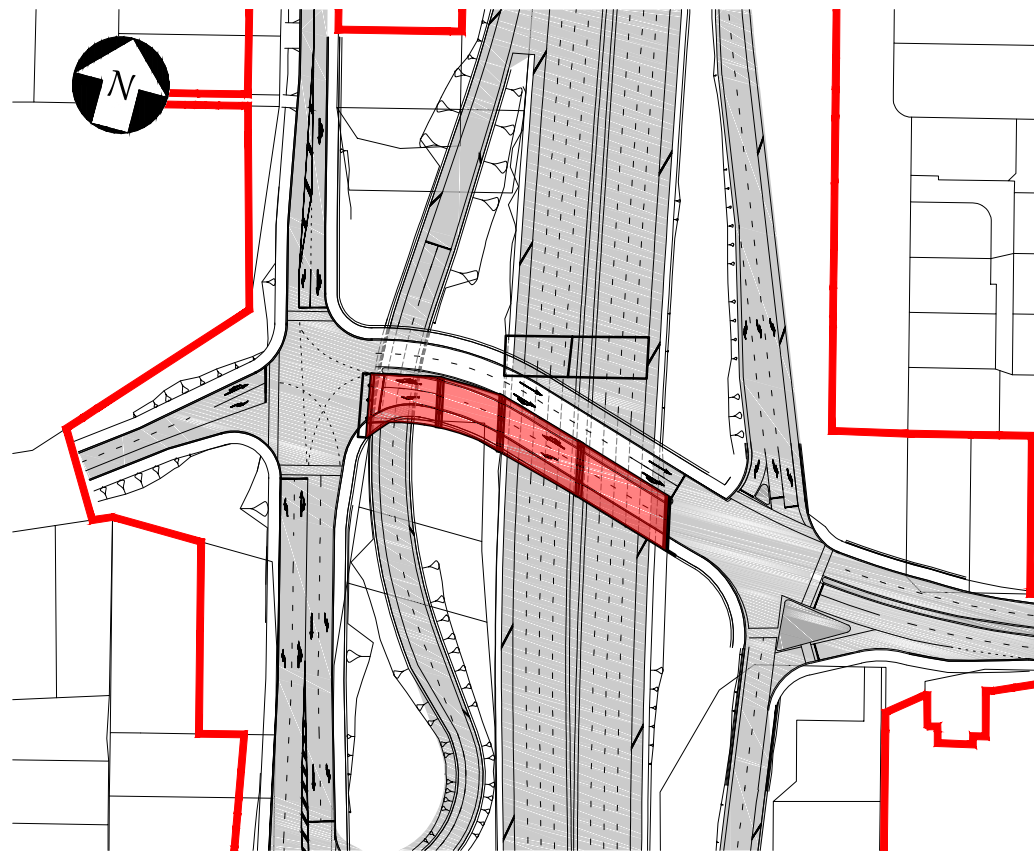

BRIDGE CONSTRUCTION
STAGE 1
SCALE 1:2000 @ A3

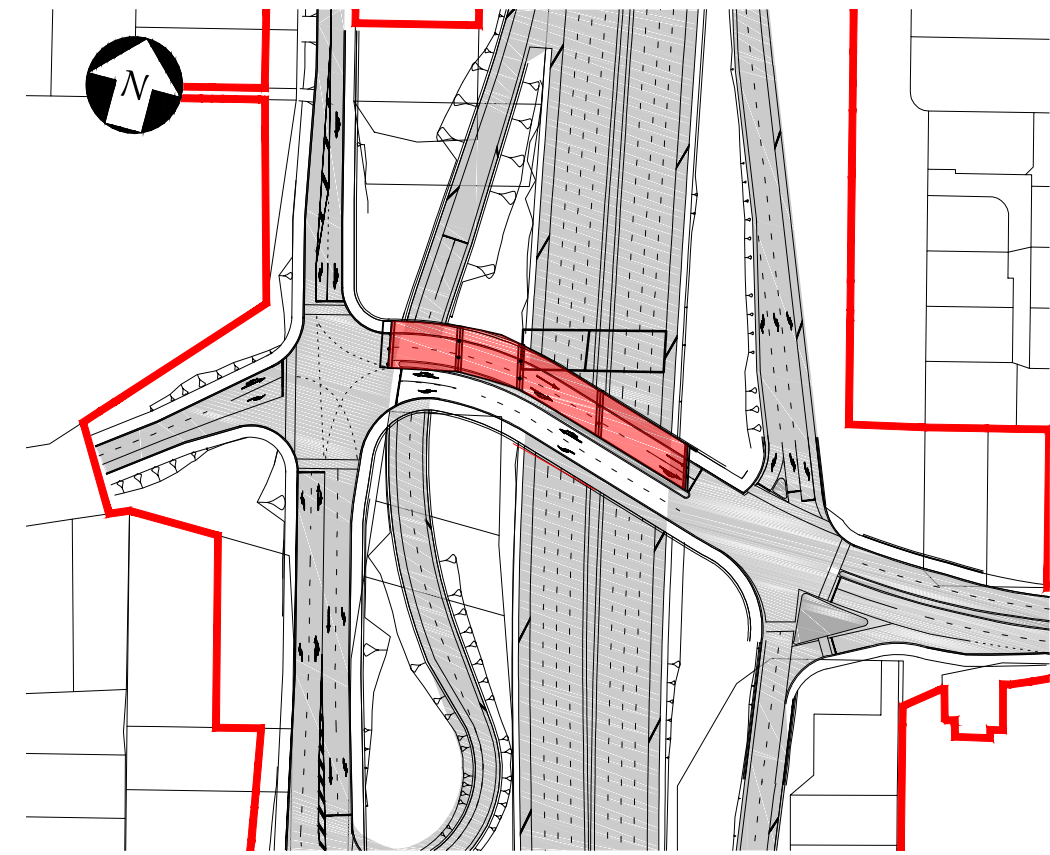

BRIDGE CONSTRUCTION
STAGE 2
SCALE 1:200 @ A3

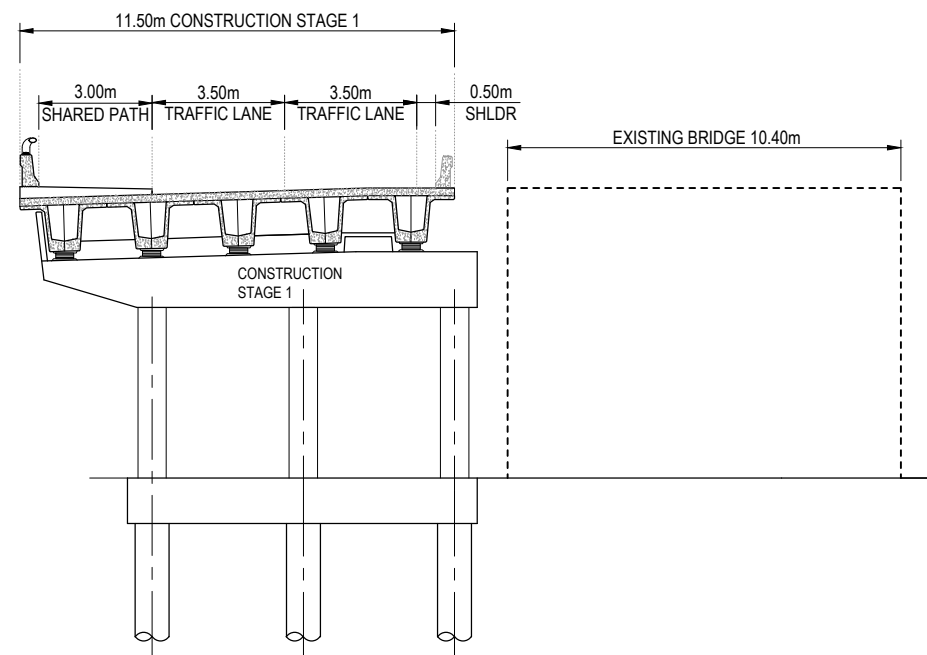

STAGE 1: CONSTRUCT 11.5m OF NEW BRIDGE

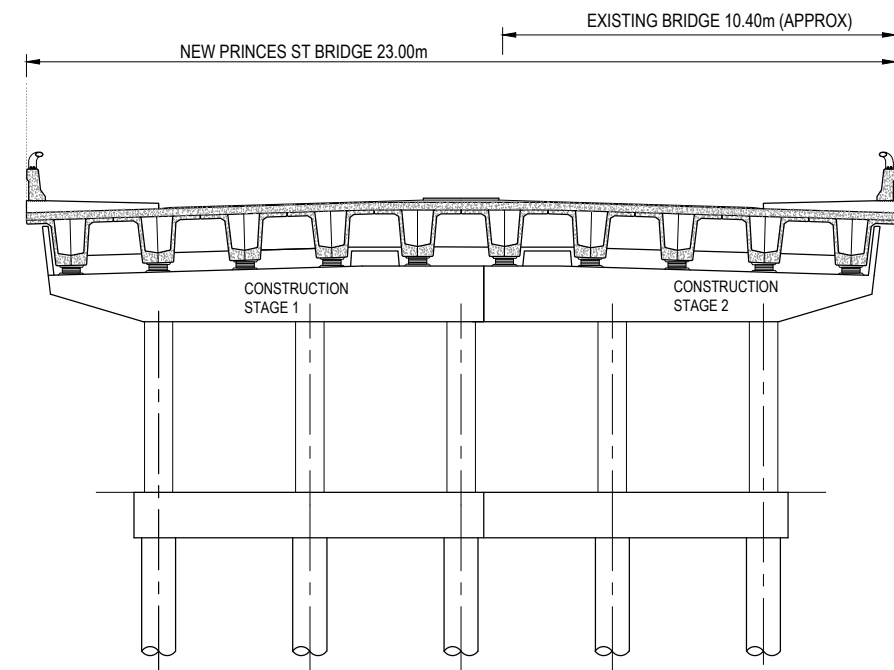

STAGE 2: DECONSTRUCT EXISTING, CONSTRUCT REMAINING

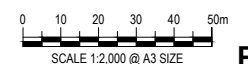

FOR BOI ISSUE

No.	Issued Status	Drawn	Check'd	App'd	Date
1	BOARD OF INQUIRY	RT	NN	JC	27.06.2017
0	ISSUED FOR CONSENT	AR	NN*	PK*	01.12.2016

DISCLAIMER
This drawing is for the purpose of supporting applications under the RMA for resource consents and designations. All information shown is subject to final design. Areas and measurements are subject to survey. Where the designs conflict with conditions the conditions will prevail. This Drawing **must not** be used for construction



Drawn	A RAM	Drafting Check	J MURAHIDY	Reviewed Design Manager	N NANCEKIVELL	Approved Alliance Manager	J CALDWELL
Designed	L COLLINS	Design Check	J MURAHIDY		27.06.17		27.06.17
Scale:	Original Scale (A1)	Reduced Scale (A3)	AS SHOWN	Contract No	PA4014		

Drawing Title	CONSTRUCTION ACTIVITIES BRIDGES ST INTERCHANGE BRIDGE STAGING PLANS			
Drawing Number	AEE-CA-203		Rev No.	1