

Traffic control devices manual

Part 3

Advertising signs

Date: May 2009

© 2009, NZ Transport Agency, www.landtransport.govt.nz

ISBN



Definitions

Term	Definition
Advertisements of a specified kind	A specific form of 'election sign' defined in the Electoral Act 1993 and controlled by the Electoral (Advertisements of a Specified Kind) Regulations 2005.
Balloon or blimp	An inflatable device raised into the sky, which for the purposes of Part 3, is used for advertising.
Banner	A rectangular device constructed of flexible material attached to supports at all four corners which is primarily used for advertising. Banners can be aligned vertically and horizontally.
Directory sign	A single advertising sign indicating a number of different businesses located at the same location in order to reduce 'sign clutter'.
Election sign	A sign advertising a political party, their objectives or any person standing for office.
Flag	A device made from flexible material attached to supports at two or three corners which, in the context of Part 3, is primarily used for advertising.
Free standing sign	A sign not installed on a building, vehicle or other structure. The structure supporting the sign is purely for that purpose.
Poster board	A structure or part of a structure upon which posters may be shown. They may include public poster boards on free standing signs or buildings through to specifically designed structures and frames for which a fee is paid (eg bus shelters).
Roadside advertising	Includes all advertising signs and devices which can or are intended to be seen by road users.
Sandwich board	A portable free-standing sign. Sandwich boards are commonly used for the purpose of advertising and are usually located on a footpath.
Sight distance	The distance over which a road user must have unobstructed sight to respond to a visual cue, or safely avoid a conflict.
Street	See 'road'
Tavern sign	An advertising sign mounted at right angles to the path of viewers enabling it to be viewed from both directions of approach. Most commonly installed perpendicular to the face of a wall or building but may be installed on a pole or over a verandah.
Territorial authority (TA)	A city council or district council named in Part 2 of Schedule 2, Local Government Act 2002.

Under veranda sign	A sign mounted below or under a veranda for the specific purpose of advertising and usually located over a pedestrian footpath.
Veranda fascia sign	A sign, other than an 'under veranda sign', mounted on any vertical face of a veranda for the specific purpose of advertising.
Video advertising	Video advertising is any video screen or variable message sign that is visible from the roadway that is used for the specific purpose of advertising.

Note: Other terms used in this document may be found in 'Definitions' found at <http://www.landtransport.govt.nz/tcd-manual/definitions.html>

Preface

Introduction

The *Traffic control devices manual* (TCD manual) will provide guidance on industry good practice, including, where necessary, practice mandated by law. The planned structure of the *Traffic control devices manual* comprises 22 parts as shown in table A.

Each part will be developed under the guidance of a working group of practitioners experienced in, and having specific knowledge about the subject. The practitioners will also be representative of the intended users of the documents. Interested practitioners and affected organisations will be given the opportunity to comment on drafts and have their input incorporated appropriately in the final document.

The *Traffic control devices manual* will be published electronically only and will be available on the NZ Transport Agency (NZTA or the Agency) website.

Relationships with other documents

The *Traffic control devices manual* will support and reference:

- New Zealand legislation and, in particular, the Land Transport Act 1998 and rules made pursuant to that act, including the Land Transport (Road User) Rule, the Land Transport Rule: Traffic Control Devices and the Land Transport Rule: Setting of Speed Limits.
- General policies contained in Austroads Guides (in particular, the *Guides to traffic management, road design and road safety*) by providing detailed guidance to meet specific requirements of New Zealand Law and practices.
- New Zealand and, as appropriate, Australian standards.
- Codes of practice, guidelines and published standards of various authorities.

Each part will attempt to provide a broad coverage of the subject but avoid duplicating major elements of referenced documents, preferring to direct readers to the source.

The *Traffic control devices manual* will, on completion, replace the Agency's (formerly Transit New Zealand and Land Transport New Zealand's) publication *Manual of traffic signs and markings (MOTSAM)*.

Part 3 Advertising signs

Advertising signs was developed with guidance from a working group representing local government (2 members), New Zealand Road Safety Manufacturers Association (2) and the NZ Transport Agency (3 – Highway Network operations [2] and Network Standards [1]). They were assisted by the contracted authors (Cherie Urlich, Tim Selby, and Sam Thornton of Opus International Consultants Ltd)

Table A Planned structure of *Traffic control devices manual*

Part	Title	Outline of content – may vary as the manual develops
	Sign specifications	Detailed descriptions of traffic signs including dimensions, colour and layout
	Signal specification	Detailed descriptions of permitted traffic signal displays and dimensions and colours of signal aspects
	Marking specification	Detailed description of road markings, including dimensions, colours and layout
1	General requirements for signs	Purposes of traffic signs and their legal foundation Materials and construction General design principles – size, lettering, legends Installation – location, mounting heights, etc
2	Direction, service and general guidance signs	Route signing, including state highways, regional roads, bypasses, detours, scenic routes, etc Street name signing, including design and location Motorist services signing policy, application and design Tourist signing General information signs, eg public amenities, features
3	Advertising signs	Design and location principles Policies for billboards and other forms of roadside advertising
4	General requirements for markings	Purposes of markings and their legal foundation Materials and some general application issues General design principles – size, lettering, legends
5	Traffic signals	Application of New Zealand legal requirements Specific applications, eg ramp signals, roundabout signals
6	Traffic control devices for general use – at intersections	Treatments at intersections, including options for traffic control, advance warning, etc
7	Traffic control devices for general use – sections of road	Treatments between intersections, including delineation, curves, passing facilities, steep grades, etc

Part	Title	Outline of content – may vary as the manual develops
8	Temporary traffic management	Included for completeness – will link to the <i>Code of practice for temporary traffic management</i> and local body supplement
9	Level crossings	Risk assessment (ALCAM) Design considerations, eg facility types, traffic movements, stacking distance, sight distances Types of control – passive or active
10	Motorways and expressways	Specific signing and marking requirements for motorways and expressways
11	Local area traffic management	Design principles LATM devices in New Zealand legal and environmental context Applications of LATM – reference examples
12	Speed	Signs and markings for speed limits Temporary and variable speed limits Advisory speeds
13	Parking controls	Legal framework – implications and responsibilities Design considerations and elements Linear and zone parking treatments Parking furniture, eg meters, vending machines
14	Special vehicle lanes	Signs, markings and surface treatments Specific applications – bus, transit, truck, cycle and other classes of lanes
15	Cycles	The extent to which issues relating to these specific classes of road user will be covered within other relevant sections of the manual is still to be determined. It is possible none of these parts will be developed.
16	Pedestrians	
17	Heavy motor vehicles	
	Definitions	Definitions of terms used throughout the <i>TCD Manual</i>
	References	All documents referenced throughout the <i>TCD Manual</i>

Contents

	Definitions	i
	Preface	iii
1	Introduction	1-1
	1.1 Purpose	1-1
	1.2 Scope	1-1
	1.3 Roadside advertising	1-2
	1.4 Judgement	1-3
2	Responsibilities	2-1
	2.1 Public roads.....	2-1
	2.1.1 Road controlling authorities.....	2-1
	2.1.2 Territorial authorities.....	2-1
	2.2 Private land.....	2-1
3	Legal framework and implications	3-2
	3.1 Legislation.....	3-2
	3.1.1 Statutes	3-2
	3.1.2 Land transport rules.....	3-4
	3.2 Relevant codes and considerations.....	3-4
	3.3 Regulation of advertising signs	3-4
	3.4 Implications of specific sign legislation.....	3-6
	3.4.1 Signs and markings – general requirements	3-6
	3.4.2 Electoral advertising.....	3-6
	3.5 Enforcement.....	3-7
4	Types of advertising	4-1
	4.1 Roadside signs.....	4-1
	4.1.1 All roads.....	4-1
	4.1.2 Specific purpose advertising signs	4-5
	4.2 General.....	4-6
	4.2.1 Vehicle mounted advertising.....	4-6
	4.2.2 Aerial displays	4-7
5	Placement considerations	5-1
	5.1 General.....	5-1
	5.2 Site selection	5-1
	5.3 Visibility of signs	5-1

5.3.1	Field of vision.....	5-1
5.3.2	Sight distances.....	5-2
5.3.3	Visibility obstruction.....	5-3
5.4	Sign position.....	5-3
5.4.1	Lateral position/clearance.....	5-3
5.4.2	Sign height.....	5-4
5.4.3	Longitudinal advertising sign spacing.....	5-4
5.5	Location in relation other road features.....	5-5
5.6	Sign supports.....	5-5
5.7	Number of signs (sign density).....	5-6
6	Sign design.....	6-1
6.1	Sign legibility.....	6-1
6.2	Sign message.....	6-1
6.3	Sign style.....	6-2
6.3.1	Colour of advertising signs and devices.....	6-2
6.3.2	Illumination and glare from advertising.....	6-3
6.3.3	Animated, flashing and variable message signs.....	6-3
6.3.4	Inappropriate advertising sign styles.....	6-4
6.4	Sign layout.....	6-5
6.4.1	Letter size.....	6-5
6.4.2	Letter style.....	6-5
6.4.3	Letter hierarchy.....	6-6
6.4.4	Sign background.....	6-6
6.4.5	Contrast between message and background.....	6-7
6.4.6	Sign reverse.....	6-7
6.5	Sign material.....	6-7
6.5.1	Reflectivity and fluorescence.....	6-8
6.5.2	Relationship with the surroundings.....	6-8
6.5.3	Sign durability.....	6-8
6.5.4	Sign costs and maintenance.....	6-8
6.6	Amenity and urban design.....	6-9
7	References.....	7-1

1 Introduction

1.1 Purpose

This document entitled *Part 3 Advertising signs* is part of a suite of guidelines within the *Traffic control devices manual* (TCD manual) prepared by the NZ Transport Agency (NZTA or the Agency). The document is intended to help provide guidance and indicate best practice on the use of advertising signs to the transport industry, territorial authorities, practitioners, and private operators. In particular, it considers both the safety and environmental or urban design issues concerning territorial authorities (TAs) or road controlling authorities (RCAs) when dealing with the effects of advertising signs.

It sets out the legal framework and responsibilities for the design and installation of advertising signs, including the general principles behind their use at the time the document has been drafted. It should not be used in substitution of professional advice as to compliance with relevant central and local government requirements.

The following terminology is used within the document to determine whether an aspect or statement made is a requirement under law or good practice. These terms are:

- **must:** indicates a statement that is mandatory/required under law
- **should:** indicates a recommendation
- **may:** indicates something that is optional and may be considered for use.

Comment: If you think a must, should or may needs to be changed to one of the other terms please provide feedback. Where there are common or strong opinions on variations this may result in a change to this document and ultimately a change to a rule.

1.2 Scope

The document seeks to incorporate links to a number of appropriate policies, standards and guidelines and forms a logical link to New Zealand practices for the Austroads *Guide to traffic management* (GTM). It should be read in conjunction with:

- legislative requirements, particularly the Land Transport Rule: Traffic Control Devices 2004 (TCD Rule) TCD Rule and the Land Transport (Road User) Rule 2004 (Road User Rule)
- New Zealand and Australian standards, particularly AS1744 *Standard alphabets for traffic signs*, AS/NZS1906.1 *Retroreflective materials and devices for traffic control purposes* and AS1742.2 *Manual of uniform traffic control devices, Part 2: Traffic control devices for general use*
- guidelines, particularly the Austroads *Guide to traffic management*, in particular Part 10: *Traffic control and communication devices*
- TA and RCA bylaws, district plans, guidelines and policies

- the New Zealand Urban Design Protocol (Ministry for the Environment). The protocol is a voluntary commitment to specific urban design initiatives by signatory organisations, which include central and local government, the property sector, design professionals, professional institutes and other groups. The protocol aims to make our towns and cities more successful by using quality urban design
- advertising codes of practice. The codes are developed by the Advertising Standards Authority to cover the entire range of advertising activity. The codes include a Code of Ethics which is the overall philosophy covering fairness, respect for people, and honest practice. The codes are to be applied in the spirit, as well as the specific requirements. The function of the codes is to complement, not to replace, the laws of the land
- other parts of the TCD manual as appropriate.

This document sets out the legal framework as well as the principles behind the use, design and installation of acceptable roadside advertising signs. It seeks to provide clear and practical guidance in providing roadside advertising that is appropriate, safe and effective from a road user perspective

This document may be used to assist in the drafting of bylaws or district plan provisions but is subject to relevant legislation, bylaws or district plan provisions relating to roadside advertising or signs in general.

1.3 Roadside advertising

The document frequently refers to 'roadside advertising'. This term is used to include all advertising signs and devices which can or are intended to be seen by all road users including motorists, motorcyclists, cyclists, pedestrians and horse riders.

Roadside advertising includes advertising that is:

- located within the road boundaries
- located on private property near a road
- permanent or fixed in nature
- temporary or movable in nature
- vehicle mounted advertising or other advertising on vehicles.

Roadside advertising may occur in the form of a sign or some other device such as, but not limited to, pavement markings, aerial displays, banners, video screen, rotating and flashing beacons.

Examples of roadside advertising include:

- balloons or blimps
- banners
- billboards
- directory signs
- election signs

- flags
- free standing signs
- posters and poster boards
- tavern signs (Figure 1.1)
- signs installed on vehicles
- veranda fascia signs (Figure 1.2)
- video advertising screens
- wall mounted signs.

Roadside advertising however does not include:

- direction and information signs described in Part 2 of the TCD manual
- displays inside buildings that may be visible from a road or other public place.



Figure 1.1 Tavern sign



Figure 1.2 Veranda fascia advertising sign

1.4 Judgement

While this document gives some specific recommendations on advertising, each particular installation should be treated on its own merits having regard to its purpose, nature and location.

This manual provides references to existing rules and guidance on the use of roadside advertising. However, practitioners, business owners, and private owners should always apply sound judgement in the use and installation of these signs to ensure they are effective but do not compromise safety at any site. For instance, the placement of a large billboard close to a driveway may need to be modified or moved even though it meets the District Plan or normal RCA requirements to provide sufficient sight visibility for drivers exiting the driveway. In such instances, judgement should be applied and any departures from recommended practice should be documented as appropriate.

2 Responsibilities

2.1 Public roads

2.1.1 Road controlling authorities

In relation to a road, the TCD Rule defines a road controlling authority (RCA) as:

- the authority, body or person having control of the road, and
- includes a person acting under and within the terms of a delegation or authorisation given by the RCA.

RCAs can be:

- territorial authorities (TAs) and regional councils
- the NZTA and other crown entities that manage and maintain roads (eg Department of Conservation)
- private landowners managing roads used by the public, including car parks, shopping centres, hospitals, universities and airports
- other private landowners.

RCAs are responsible for approving road side advertising (design and location) and removing non-complying roadside advertising located within the road reserve under their control unless delegated to the local TA.

2.1.2 Territorial authorities

TAs are responsible for approving advertising that may be located beyond the road reserve but which can still be seen by passing road users. Policies relating to the placement, provision and location of such advertising are typically set down in the TAs District Plan.

2.2 Private land

Owners of private land, such as universities, hospitals, airports and shopping centre car parks may be considered RCAs with respect to the TCD Rule. They have the authority to control the location and content of roadside advertising signs on their land.

There is a legal obligation on property owners to conform to the TCD Rule. Inappropriate use of roadside advertising signs on their property may lead to a misinterpretation by road users and create a potential for risk, conflict or injury. On entering a 'private' site, users may reasonably expect a similar approach to the provision and use of advertising signs as those found on public roads.

3 Legal framework and implications

3.1 Legislation

Some legislation relevant to controlling roadside advertising is described briefly below.

3.1.1 Statutes

Land Transport Act 1998

This Act is intended to:

- promote safe road user behaviour and vehicle safety
- provide for a system of Rules governing road user behaviour, the licensing of drivers and technical aspects of land transport; and to recognise reciprocal obligations of persons involved
- consolidate and amend various enactments relating to road safety and land transport
- enable New Zealand to implement international agreements relating to road safety and land transport.

The portion of the Act which relates to roadside advertising signs is Section 152 which describes the power of the Minister to make ordinary Rules - in this case, the TCD Rule which outlines some requirements for advertising signs as described above.

Local Government Act 1974 and 2002

The Local Government Act (LGA) provides the general framework and powers under which New Zealand Territorial Authorities (TAs) operate, and is designed to provide a democratic and effective territorial government recognising the diversity of New Zealand communities.

In relation to roadside advertising signs, the LGA sets out the general powers of TAs, including the setting of bylaws. Section 684(15) of the Local Government Act 1974 permits territorial authorities to make bylaws to regulate, control or prohibit outdoor advertising.

Government Roadway Powers Act 1989 (formerly Transit New Zealand Act)

The Act gives NZTA the power to set bylaws to control roadside advertising on state highways.

Building Act 2004

When the installation of a large sign (such as an advertising sign, billboard, etc.), freestanding sign or sign attached to a building is proposed alongside a public road information should be sought from the appropriate TA or RCA on the maximum size of the structure allowed and if building consent is required.

Transport Act 1962

This was the principal Act for general land transport safety matters. Most of its original provisions are now included in the Land Transport Act 1998 but it still includes relevant sections in relation to the development of some traffic bylaws.

Land Transport Management Act 2003

This Act sets out the requirements and processes for local authorities to obtain funding for road construction and maintenance, and for the funding of Police on-road enforcement.

Resource Management Act 1991

The Resource Management Act (RMA) requires the preparation of District and Regional Plans and outlines the requirements for resource consent. Whether resource consent is required and what type of consent is needed depends up the type of activity that is proposed and how the activity is classified in the relevant council plan.

For the purposes of this document, the RMA specifically relates to the placement and type of signs located within the road environment and whether the requirements of the District or Regional plans are met. In particular, environmental considerations will differ in commercial, residential and rural areas. In many instances, meeting environmental requirements may be more difficult than meeting safety requirements. To a large extent, the characteristics of advertising that are likely to have an adverse effect on traffic are also those that have an adverse effect on the environment.

Any person considering installing a sign should seek advice/confirmation from the TA as to whether resource consent is required. If resource consent is required, then it is likely that the written approval of the RCA will also be required if it considered there may be an impact on traffic safety.

Electoral Act 1993

The Electoral Act 1993 and regulations made pursuant to it controls the form electoral advertising used in central government elections may take and the periods during which it may be shown.

The Electoral Act sets out legal requirements regarding electoral finance issues related to election activity including use of roadside advertising. Any regulation related to the design, layout, shape and colour of advertisements of a specified kind may only be made for the purposes of ensuring the advertisement does not endanger the safety of road users and is restricted to a 2 month period prior to polling day.

The Electoral (Advertisements of a Specified Kind) Regulations 2005 applies:

- to election signs displayed in a public place or on private property that do not exceed 3 m² but are more than 1500 cm² in size
- during the period 2 months before polling day and ending with the day before polling day.

More specific requirements are described in 3.4.2 below.

Other election signs are not precluded but these are subject to normal application and approval by RCAs.

Forest and Rural Fires Act 1997

The Forest and Rural Fires Regulations 2005 made pursuant to the Forest and Rural Fires Act permits the use of National Rural Fire Authority (NRFA) and NZTA approved regulatory and general fire authority signs (see section 4).

3.1.2 Land transport rules

Land Transport Rule: Traffic Control Devices 2004

The TCD Rule describes the requirements for the design, construction, installation, operation and maintenance of traffic control devices and makes comment on the use of signs that are not traffic control devices – such as advertising signs and on road markings used for advertising purposes. The implications of the TCD Rule with respect to advertising is discussed in detail in Section 3.4

Land Transport Rule: Road User Rule 2004

The Road User Rule stipulates how traffic must legally operate on the road and applies to all road users. In relation to advertising signs this rule covers the use of beacons and other light equipment on motor vehicles.

3.2 Relevant codes and considerations

The Heavy Vehicle Visibility Code

This code, developed by the NZTA (formerly LTSA), outlines minimum requirements and provides recommendations for heavy vehicle visibility. In particular the code provides information on the use of lighting, retro-reflective material and advertising displays.

Advertising Standards Authority Code of Ethics

The prime function of the Advertising Standards Authority (ASA) is to self-regulate advertising in New Zealand. The Advertising Code of Ethics provides rules by which advertisements in all media should comply (see www.asa.co.nz).

All advertisements should adhere to the principles and guidelines set out in the Code. Basic principles are:

- all advertisements must comply with the laws of New Zealand
- no advertisement should impair public confidence in advertising
- no advertisement should be misleading or deceptive or likely to mislead or deceive the consumer
- all advertisements should be prepared with a due sense of social responsibility to consumers and to society
- all advertisements should respect the principles of free and fair competition generally accepted in business.

Urban Design Protocol

When developing and designing advertising signs, certain environmental aspects should be considered to ensure they blend into the surrounding facilities and provide a certain level of 'attractiveness' to road users. Further information is provided within the New Zealand Urban Design Protocol.

3.3 Regulation of advertising signs

The legislation listed in section 3.1 provides TAs with the power to make bylaws to control roadside advertising. As part of this, district planning documents or bylaws typically set out the number, location, size and form of advertising signs permitted along with any specific restrictions or requirements. District

plans should recognise most forms of roadside advertising are legitimate activities and they should therefore make provision for such advertising without compromising objectives of controlling adverse effects on safety, amenity and the environment.

RCA's such as the Agency and TAs should set out their own rules and policies with respect to roadside advertising. For instance, the Transit NZ (Signs on State Highways) Bylaw 2003/13 provides specific conditions of consent for the application of roadside advertising signs within the state highway reserve while policies are set down in their *Policy planning manual*. Furthermore, the *State highway control manual* provides advice and guidance for use of fire authority signs, election signs and road safety billboards for staff, consultants, TAs and other agencies involved in the management of state highways. The Agency also provides guidance for TAs on suggested conditions and restrictions of use of signs adjacent to the state highway reserve.

Advertising signs on state highway road reserves outside urban areas are controlled by the Agency through their Signs on State Highways Bylaw 2003/13. The bylaw can be applied to state highways in urban areas if adopted by a TA to apply in those circumstances. However, in urban areas, TAs typically manage and enforce advertising signs on the state highway network using their own policies and guidelines.

In formulating proposals to install new advertising signs at sites near a state highway, consultation between the TA and the Agency at an early stage is strongly recommended. This will not only clarify TA and RCA requirements but will also assist in ensuring an appropriate result is achieved.

Rules and policies relating to roadside advertising vary between TAs as well as RCA's. To assist the various authorities this document sets out a number of issues that should be considered when developing policies and rules relating to roadside advertising.

In meeting some of the demand for advertising by leasing or licensing sites within road boundaries, there is scope for the RCA to have more control over the design, construction and location of signs and other devices than there would be if the signs were located on private land. This can have a positive effect where appropriate advertisements replace others which may be poorly designed or located from a safety viewpoint. There are a number of suggestions worth consideration by TAs in this regard.

- Advertising devices, particularly portable ones such as sandwich boards may be permitted within the road boundaries by means of a licensing system. Here the TA issues a permit for a particular device and a sticker that must be displayed on the device.
- Suitable sites may be selected for the installation of long term or permanent advertisements such as billboards and banners. For example, anchor points for banners could be installed at selected sites or permanent frames installed for billboards.
- Revenue for road safety or road maintenance may be raised from the issuing of permits or from leasing suitable space on the roadside for advertising purposes.
- Developing an advertising signs bylaw which allows the TA to regulate licensing.

3.4 Implications of specific sign legislation

3.4.1 Signs and markings - general requirements

Clause 4.7 of the TCD Rule states *'a sign, hoarding or similar structure used or intended to be used for the purposes of advertising must not contain reflective material if it is likely to reflect the light from the lamps of any vehicle on the road; or fluorescent or phosphorescent material if it is likely to mislead or distract drivers from traffic signs installed in the vicinity or mask those signs.'*

Furthermore, sub-clause 3.2 (5) of the TCD Rule states that *'a person must not install on a road, or in or on a place visible from a road, a sign, device or object that is not a traffic control device, but that may be mistaken for a traffic control device; or may prevent the traffic control device from complying with 3.1(a) to (d)'* (ie the general safety requirements for traffic control devices) (Figure 3.1).

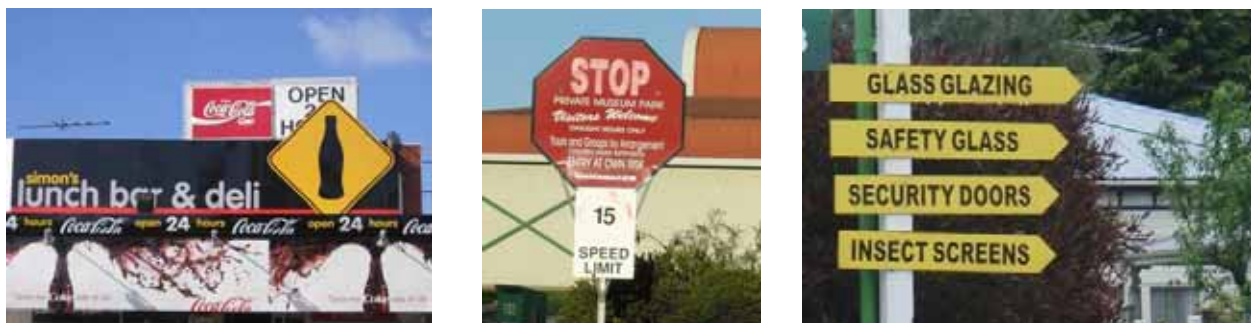

Figure 3.1 Examples of advertising signs made to look like traffic signs which is not permitted

In addition, Clause 5.5 states *'a person must not install, on a roadway, a marking that is intended to be used for the purpose of advertising or other purpose not connected with the use of the road.'* Of note in this regard are recent road safety campaign pavement markings involving 'chalk' outlines of bodies beside pedestrian crossings (Figure 3.2). While such markings are intended to communicate a road safety message, from a legal perspective, they are considered advertising and are therefore not strictly legal. If such markings were located on the footpath, they would not contravene the rule.

Under Clause 13.7 (d) of the TCD Rule, advertising on traffic signs is not permitted. No person shall *'install a traffic control device that bears a logo, monogram, sign of sponsorship, sign indicating an association with a business, or any information other than that specified in this rule.'*



Figure 3.2 Road safety advertising campaign marked on the road (source www.flickr.com)

3.4.2 Electoral advertising

'Advertisements of a specified kind' installed on any road or in any place visible from a road must not (Electoral Act 1993):

- be made of, or have affixed to it, any reflective material that is likely to reflect the light from the headlights of any approaching vehicle
- be internally illuminated by any means
- be externally illuminated by any artificial lighting that is designed specifically to illuminate the advertisement.

Such advertisements must not be installed on any road or in any place visible from a road if they are:

- similar to or the same as any traffic sign in its shape and colour, and
- liable to be mistaken for a traffic sign.

Advertisements of a specified kind installed on any road or in any place visible from a road must not:

- have information displayed by means of a flashing or revolving mechanism
- have, or have affixed to it, any moveable part intended to draw attention to the advertisement.

On state highways controlled by the Agency the following requirements for advertisements of a specified kind are imposed by the Electoral Regulations 2005.

- Lettering must not be less than:
 - 120 mm in height where the advertisement of a specified kind is installed on any road, or in any place visible from a road with a speed limit less than 70 km/h
 - 160 mm in height where the advertisement of a specified kind is installed on any road, or in any place visible from a road with a speed limit of 70 km/h or more.
- The spacing between lines of text must be not less than 50 mm.

These requirements for Agency controlled state highways do not apply to:

- lettering on any party logo displayed if the logo has been registered by the Electoral Commission under section 67A of the Electoral Act 1993
- the statement included, as required by section 221 of the Electoral Act 1993, setting out the true name of the person for whom or at whose direction it is published and the address of his or her place of residence or business
- any advertisements of a specified kind published in the form of a poster less than 1500 cm² in size.
- The main thrust of this regulation is to enable standard signs meeting the stated requirements to be developed by political parties and installed in any TA or RCA area subject only to location and numbers at any site. Any signs which fall outside the requirements of the regulation are subject to application to, and any conditions imposed by, the TA or RCA.

3.5 Enforcement

In order to create an environment of safe and successful roadside advertising, it is necessary to effectively enforce the provisions for that advertising. This should not simply be a matter of implementing and enforcing bylaws and district plan rules to complement national legislation or rules in restricting roadside

advertising. It should also involve making positive provision for and facilitating the installation of quality roadside advertising especially where it is replacing poorly maintained or inadequate signs.

Enforcement needs to be strong in relation to 'unwanted' advertising whether it is hazardous or simply poorly maintained. Examples include flashing or variable message signs (VMS) at intersections which add to the confusion when the driver has to make a number of other important decisions (Figure 3.3). Incentives to replace such advertising with well-designed and located signs should be considered and new advertising of this type discouraged at inappropriate locations. Such incentives could include trade-offs in the allowable area of signage for an improvement in quality.

In many instances, TAs should be pro-active, for example in bringing together groups of businesses with a view to replacing existing conglomerations of signs with directory boards or other orderly displays (Figure 3.4). Such action would be in the interests of those businesses as well as passing road users.

In relation to vehicle-mounted signs, action by the police and parking wardens (as appropriate) in dealing with vehicles which are illegally or dangerously parked and the inclusion of appropriate provisions in TA bylaws may assist in this area.

With any type of rule, enforcement must be undertaken to effectively manage the use and potential overuse of advertising signs. Without enforcement, business owners can become complacent and measures put in place to manage safety and minimise environmental effects will not be as effective.

Enforcement of these bylaws is normally undertaken by a bylaws enforcement officer of the TA. Enforcement can be undertaken by the New Zealand Police where the sign may pose a risk to road users, or where certain regulations exist, such as the use of flashing lights or beacons on vehicles.

In relation to state highways, the Agency typically delegates its authority to the TA in urban areas. However, in rural areas, the network maintenance contractor or consultant is typically responsible for the monitoring and enforcement of advertising signs.



Figure 3.3 Large video/VMS signs located at busy city intersection facing oncoming traffic.



Figure 3.4 Directory board showing various stores rather than using individual advertising signs

4 Types of advertising

4.1 Roadside signs

4.1.1 All roads

Advertising signs and markings must not:

- obscure or cause confusion with any official road sign or traffic sign
- cause alarm or unduly attract the attention of people operating vehicles on the road
- create or contribute to a traffic hazard (such as restricting sight visibility)
- compromise the safe and efficient operation of the road network
- be contrary to any relevant legal requirements.

Advertising signs and markings should not:

- physically obstruct the movement of road users
- be permitted on the vehicle carriageway, on any traffic island or extended kerb-line within the vehicle carriageway, or at a height of less than 5.5 m above the carriageway. This does not apply to signs mounted on bridges where the absolute minimum clearance is 4.9 m (or to vehicle-mounted signs that comply with section 4.2).

In general, advertising signs can be adequately controlled by provisions on their number, location, size and form. Control over the content should refer Advertising Standards Authority Code of Ethics (Section 3.2)

Each installation should be considered on its own merits, and any specific controls on advertising will need to be tempered with provisions by the TA or RCA to prohibit or to remove installations which may have road safety issues or whether its location is considered appropriate from an urban design/environmental perspective. All advertising signs need approval from the appropriate authority.

Election signs

Comment. Specific requirements for central government election signs have been covered at 3.4.2. This does not cover any rules that should or could apply to local government elections. Should this issue be covered here? Your comments would be welcomed.

Real estate signs

Many TAs have guidance on the use of real estate signs, especially with respect to the size, number and placement of the signs. Where specific guidance does not exist, requirements for temporary signs or general advertising signs can generally be applied.

Typical requirements for real estate signs should include reference to portable open home or auctions signs and flags as well as direction signage. Such guidance should relate to:

- the number and size of real estate signs or flags
- permitted time restrictions on the provision of real estate signs
- the positioning of the sign within the property boundary including mounting height
- information permitted on the real estate sign, flags and directional signs
- the positioning of any flags either within the property boundary or attached/secured to vehicles
- positioning of signs or flags with respect to causing inconvenience to road users or a road safety hazard (eg restricting pedestrian, or cyclist movements or reducing sight line visibility)
- the number and permitted location of directional signs for a single property as well as time restrictions on their use
- size and mounting height of directional signs
- the number of directional signs for different properties at the same location/intersection
- the form of the mounting of any directional signs.



Figure 4.1 Typical real estate sign

Billboards

The use of billboards is determined by the RCA or TA. Further information on the use and size of billboards can be found in TA guidance and policy documents, for example, guidance on road safety billboards for state highways can be found in Chapter 3 of the NZTA *State highway control manual*.

Billboards can be used in both urban and rural environments. However, there is a need to take into account varying approach speeds and surrounding environmental conditions.

- **Urban environment** - billboards in urban environments (less than 70 km/h) are primarily subject to local TA controls. The criteria for their use tends to relate to their placement among other signs, placement on building, the significance of traffic safety issues such as potential distraction to road user and placement on footpaths.
- **Rural Environment** – billboards in rural environments (70km/h or more) are more subject to safety issues such as type of construction (ie providing frangible structures within clear zones), appropriate letter heights and length of message so they can be easily read at higher speeds and adequate sight distance to read the sign. Under the existing NZTA bylaw, it should be noted billboards must not be placed on or over Motorways.



Figure 4.2 Examples of types of billboards.

Advertising installed on footpaths

Advertising installed on footpaths include free-standing signs (Figure 4.3) and sandwich boards (Figure 4.4).

Where advertising is permitted on footpaths conditions applicable to their use should include:

- location relative to the site to which it refers (for instance being no more 50 m from the site)
- size of the sign or device
- the need to avoid obstruction to any bus stop, taxi stand, loading zone, parking meter, etc
- the width of any footpath or other pedestrian way used by pedestrians should not reduce to less than 2 m
- the sign should not have any sharp edges, projections or moving parts which may be a nuisance or danger to vulnerable road users
- the sign should be constructed to be secure against wind gusts
- sight distance requirements.



Figure 4.3 Free-standing sign



Figure 4.4 Sandwich boards blocking footpath

Many TAs have specific policies in relation to licensing for the use of signs on footpaths.

The NZTA *Pedestrian planning and design guide* suggests advertising installed on footpaths may be placed in the kerb, street furniture or frontage zones but should not be placed in the 'through route' as this may significantly affect visually and mobility impaired road users. The recommended 'through route' width depends on the road classification and the pedestrian demand (refer to the guide for further information - although the absolute minimum suggested is 1.5 m).

Advertising installed on buildings

Advertising installed on buildings includes any of the following which may be mounted on a building:

- banners
- billboards
- wall-mounted signs (Figure 4.5)
- posters
- tavern signs
- under veranda signs (Figure 4.6)
- veranda fascia sign
- flags
- directory signs
- video advertising.

Some TA rules, guidelines and bylaws provide guidance or requirements for placement of advertising signs on buildings to ensure the character of the building and the surrounding area is not compromised. Other general requirements include the need for projecting signs to have sufficient vertical clearance over footways and not cause inconvenience to road users and road safety hazard.

Advertising installed on other structures

Roadside advertising may be installed on other structures such as power poles, light columns and bridges. Some of the signs that may be mounted on these other structures include:

- horizontal and vertical banners (Figure 4.7)
- flags.

Banners are classified as portable advertising devices, and in many instances they will be displayed on the business premises to which they relate. In this regard they may be treated in a similar manner to other more permanent displays.

Banners may also be located above the roadway. It is suggested that TA's could cater for the demand for banner advertising over the roadway by setting up a small number of specific sites where banners may be installed such as the sides of over-bridges (Figure 4.8).



Figure 4.5 Wall mounted sign



Figure 4.6 Under veranda sign



Figure 4.7 Vertical banners



Figure 4.8 Banner on bridge

Recommended conditions specifically applicable to the installation of banners are:

- their locations should comply with all the recommended conditions in section 5 of this guideline
- mid-block locations are preferred as they generally maximise the distance from adjacent intersections and access ways to major traffic generators
- they are installed to ensure the bottom of the banner does not hang lower than 5.5 m above the carriageway at any point
- anchor points are constructed to withstand wind gusts and banners should not tear or flap in the wind; air holes may be necessary
- they should not be installed on roads forming part of designated routes for over dimension loads (this information may be sought from the RCA)
- they must not impair the effective operation of signs, signals, street lights or other control devices
- the sign meets the first or second schedule of the NZTA Signs on State Highways Bylaw 2003/13
- the sign meets the requirements of the TA.

NZTA consent is not required behind the kerb-line of state highways in areas where a 50km/h or lower speed limit applies.

4.1.2 Specific purpose advertising signs

In addition to commercial advertising, a number of advertising signs providing important information to road users exist. These include construction site signs and fire authority signs.

Construction site signs

The installation of construction site signs should be considered where the construction period exceeds one month. These signs should always remain for the duration of the construction period.

Fire authority signs

The installation of fire authority signs are permitted where deemed appropriate. The types of signs are approved under the Forest and Rural Fire Regulations 2005 by the National Rural Fire Authority (NRFA). There are three types of signs approved by the national rural fire advisory committee. They are:

- NRFA approved national standard signs (Regs 52(3) and 53(3))
- NZTA approved national standard, and



Figure 4.9 Flag



Figure 4.10 Construction site sign



Figure 4.11 Fire hazard sign

- NRFA approved other national standard.

Specific information on these types of signs may be sourced at:

<http://www.nrfa.org.nz/Firenet/Regions/Rural/Information/Circulars/11.htm>

When adjacent to a state highway they should preferably be installed outside road reserve.

Fire Authority signs are generally requested by regional councils, fire departments or the NRFA. In many instances, TAs have a standard procedure to approve such signs. Some types of signs will also only be used temporarily.

General fire authority signs include:

- 'Light No Fires' - triangular signs proclaiming a prohibited fire season
- 'Fire Hazard' - signs advising of current fire danger) (Figure 4.11).

Regulatory fire authority signs also exist:

- 'Fire By Permit Only' (Figure 4.12)
- 'Total Fire Ban'.



Figure 4.12 Example regulatory 'Fire by permit only' sign



Figure 4.14 Business-related advertising

4.2 General

4.2.1 Vehicle mounted advertising

Three types of vehicle mounted advertising can be defined:

- business-related advertising
- advertising incidental to the vehicle's operation, and
- advertising as the purpose for the vehicle.

Business related advertising

This refers to vehicles where the advertising on the vehicle specifically relates to the vehicle doing the advertising. Examples of this include couriers, plumbers vans. (Figure 4.13)

Advertising incidental to operation

This type of vehicle mounted advertising refers to vehicles which display advertising which does not refer to their normal purpose. Examples of this include buses which are painted to advertise various products and services. (Figure 4.14)



Figure 4.14 Advertising incidental to operation



Figure 4.15 Advertising as the purpose

Advertising as the purpose

Examples include semi-permanent vehicles parked on or adjacent to the road such as trailers or motorised vehicles. Other examples include vehicles and trailers which drive around for the specific purpose of showing their advertising. Semi-permanent advertising specific vehicles (with vehicle mounted advertising) are banned by many RCAs from parking on the road or road reserve for the specific purpose of advertising.

General considerations

Recommended conditions for the use of vehicle-mounted signs include the following.

- They should comply with all other recommended conditions for location and design in sections 5 and 6.
- They must not be designed so the content resembles a traffic sign nor should they include any traffic sign other than any approved to installed on a vehicle for that purpose by the TCD Rule.
- They must not be designed or displayed in any way that could confuse other motorists over which way the vehicle is facing.
- They must not display any markings making the vehicle look like any emergency services vehicle.
- They must not display retroreflective material, paint or lighting that could cause confusion over the true size of the vehicle.
- They should not mask or obscure any part of a vehicle required for the safe and legal operation of the vehicle – for instance brake lights or number plate.
- They should create no more of a physical obstruction or visibility obstruction than the vehicle would without the sign or signs mounted on it.
- They should not have any sharp edges, projections or moving parts which may be a nuisance or a danger to road users including pedestrians and cyclists.
- They should be constructed and mounted so as to be secure against wind gusts whether stationary or when the vehicle is in motion as appropriate.
- They must not impair the effective operation of signs, traffic signals, street lights or other traffic control devices.
- Neither vehicle nor sign must impair the legitimate use and expectation of parking provisions, such as parking over two car parking bays.
- Flashing lights cannot be used on vehicles to promote vehicle mounted advertising as stated in clause 8.5 of the Road User Rule 2004.

4.2.2 Aerial displays

It is recommended TA's discourage the use of these devices in all forms. By their nature, they are very likely to cause distraction to motorists and, because they are usually visible from a great distance, it is almost impossible to impose conditions on their use that will limit this distraction.

Comment: This section could include material covering other forms of advertising such as short-term, private posters (eg garage sales); formal public notices (eg notification of planning applications); community

notices (eg school anniversaries, public events) and public information (eg water restrictions, poison bait drops). Event signing and advice of planned road works are examples more appropriately covered by the Code of Practice for Temporary Traffic Management. Your comments are welcome.

5 Placement considerations

5.1 General

The primary issues when installing a roadside advertising sign relates to its location in terms of the overall environment and its location with respect to any adjacent roads.

Roadside advertising signs will have a greater impact in terms of the effectiveness of the message, the effect on safety, and amenity of the sign in some environments compared to other. For example, the message on a sign in isolation in a rural environment may have a greater impact than the same sign in a commercial urban environment - where it is surrounded by other competing signs. However, it may not necessarily adversely affect passing road users - as such road users are likely to have less competing demands for their attention in a rural environment.

5.2 Site selection

It is in the interests of all interested parties to consider the visual and safety impact that the sign is likely to have on the surrounding environment when seeking to install and/or approve an advertising sign location. The visual and safety impacts will differ depending on whether the sign is located in the rural or urban environment.

Many businesses and organisations desire advertising signs outside their property. In many cases, this idea is supported by RCAs which have guidelines or requirements that signs should only be placed outside the properties for which they are advertising.

Businesses and organisations wishing to advertise in locations remote from their property should seek approval from relevant landowners as well as the TA.

Comment: Is there a need for further information in here? Some general requirements and advice is needed - however each TA or RCA has varying criteria and requirements. The NZTA would be interested in any comment on this.

5.3 Visibility of signs

5.3.1 Field of vision

Two relevant factors to consider in locating signs concern the speed at which traffic passes the site of the sign. As travel speed increases:

- a driver's concentration increases and the point of concentration recedes meaning signs must be visible from a greater distance on roads with higher operating speeds
- a driver's peripheral vision decreases (see Figure 5.1).

A consequence of these issues is that signs should be placed as close as possible to drivers' lines of sight while maintaining the clearances from the roadway recommended in section 5.4.

Figure 5.1 – Extent of a drivers field of vision

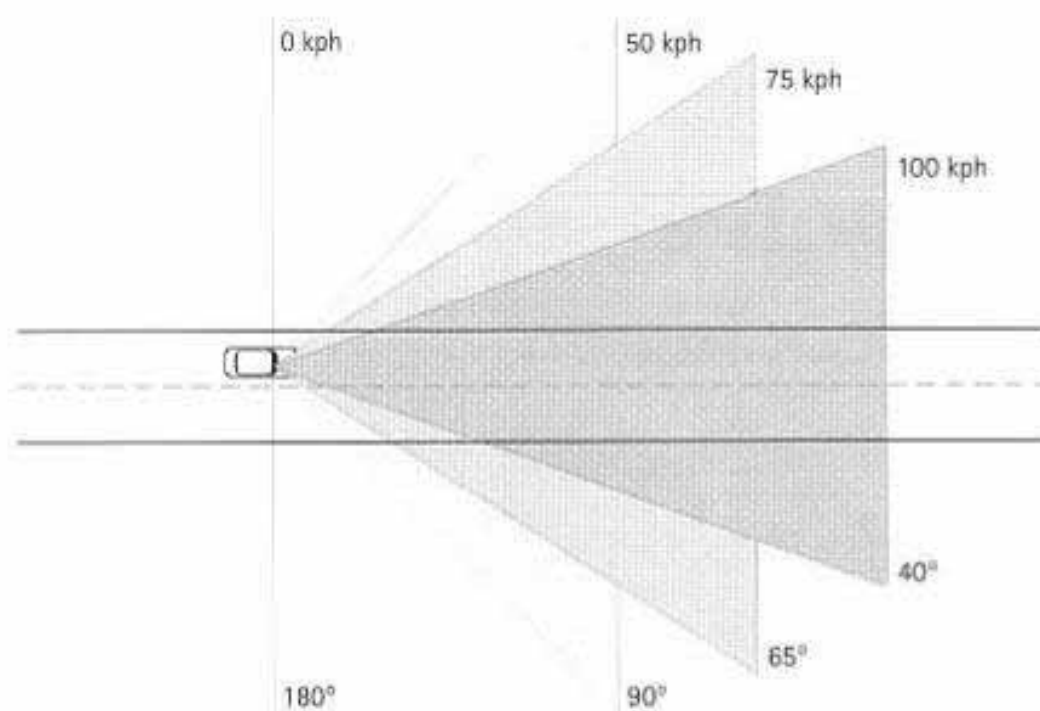

Note: to make allowances for drivers to move their heads, 15° may be added to both the left and right hand sides of the fields of view.

In urban areas where speeds may be less than 50 km/h, the field of vision is quite large – but there is generally more sign clutter which may reduce the effectiveness of a particular advertising sign.

5.3.2 Sight distances

To ensure roadside advertising signs can be seen by the road user, they should be located to present an unrestricted view to the approaching motorist. Suggested minimum forward sight distances along the road for roadside advertising signs for different speed limits are shown below in table 1.

Table 5.1 - Minimum forward sight distance to roadside advertising signs

Posted speed limit (km/h)	Minimum visibility (m)
50	80
60	105
70	130
80	175
100	250

5.3.3 Visibility obstruction

In the same manner as other roadside features, roadside advertising may create restrictions to sight visibility, and create a safety hazard if it obstructs or interferes with:

- road users' view of a road hazard, person or oncoming vehicle on the roadway
- road users' view of a person or vehicle about to enter the roadway.

The general requirements for maintaining sight distances at driveways and intersections therefore need to be applied to roadside advertising. Table 5.2 sets out the safe intersection sight distances for a range of speed limits. The distances shown relate to the absolute and desirable sight distances along the major road from 5 m (3 m minimum) back from the major road. Corrections to the distances shown in Table 5.2 need to be undertaken for gradients greater than 2% (refer to GTEP Part 5).

Table 5.2 – Safe Intersection Sight Distance (Austroads GTEP Part 5)

Posted speed limit (km/h)	Absolute minimum (m)	Desirable minimum (m)
50	89	96
60	113	121
70	140	149
80	170	181
100	240	253

In general, visibility problems will not be caused by signs or devices which are:

- less than one metre in height, except where they are likely to obscure children
- the bottom of the sign is more than three metres above the level of the roadway.

Some of the more common situations where there is potential for visibility problems include:

- vehicle-mounted signs
- portable signs placed on footpaths, shoulders or grass berms
- signs adjacent to driveways particularly of major traffic generators, eg service stations
- signs close to intersections or curves in the roadway.

5.4 Sign position

5.4.1 Lateral position/clearance

Lateral clearance distances are controlled by a number of different factors:

- Whether the sign is allowed within the road reserve.
- Whether appropriate clear zone requirements are met (refer TCD manual Part 1).
- Whether the sign can be seen within the driver's field of vision (section 5.3.1).

The minimum lateral clearance distance between an advertising sign and the edge of the carriageway for roads with a speed limit of 60 km/h or less should be 1.5 m. This minimum distance increases to 3m for roads with a speed limit greater than 60 km/h. The NZTA Signs on State Highways Bylaw 2003/13 requires signs to be located not closer than 5 m from the edge of the carriageway.

Signs mounted adjacent to footpaths and other public places can obstruct pedestrians, can cause visibility problems and are potentially dangerous to visually impaired pedestrians. To overcome these problems:

- no advertising sign or device, whether temporary or permanent, should be located on or above a footpath or berm closer than 500 mm to the kerb face or the edge of the vehicle carriageway
- a wall sign or vertical projecting sign mounted on a fence, building or similar should not project more than 50 mm from the building frontage if less than 2.5 m above ground level.

TAs in urban areas often have requirements for minimum footpath widths that have to be maintained. This will often restrict the placement of advertising signs in those locations.

5.4.2 Sign height

In locations where the signs are installed above an area used by pedestrians such as footpaths, the recommended vertical clearance is 2.5 m with an absolute minimum of 2.1 m (NZTA *Pedestrian planning design guide*). Recommended sign heights however may be sourced from individual TA bylaws and policies.

As discussed in section 4.1.1 signs or banners over the roadway are generally discouraged unless they are placed on the sides of footbridges or similar. In these locations, the minimum vertical clearance is 5.5 m.

5.4.3 Longitudinal advertising sign spacing

Sufficient longitudinal spacing between roadside advertising signs is important to reduce visual clutter and ensure the driver has sufficient time to process the information that is being presented. Table 5.3 shows the recommended spacing between roadside advertising signs for different operating speeds. Recommended distances to other roadside features are detailed in section 5.5.

Table 5.3 – Minimum distances between adjacent roadside advertising signs

Posted speed limit (km/h)	Minimum recommended spacing (m)	Desirable spacing (m)
50	50	80
60	55	100
70	60	150
80	70	200
100	80	250

The spacing is based on the time taken for a road user to read and assimilate signs of the maximum recommended complexity. They may not be achievable in many circumstances, such as those in lower speed, urban areas (eg 60 km/h or less). However, where they are, both advertisers and road users will benefit from the resulting layout.

5.5 Location in relation other road features

Where routes are defined by an RCA or TA as being major roads the installation of advertising signs should generally be a discretionary activity. Although there are many advertisements close to intersections or traffic control devices (eg in central business districts) apparently causing no problems, these advertisements may still cause a distraction to road users. Hazardous situations can arise as a result of a lack of road user (driver, pedestrian, and cyclist) concentration or excessive demands on road users at the location. TA's should use their discretion to control unnecessary distractions which may contribute to collisions at such locations.

Location and orientation relative to the road

The location, orientation and design of advertising signs in relation to the road should be assessed to ensure advertising signs can be read without a motorist having to slow down or stop their vehicle. (Refer to section 6 regarding sign design).

Location of advertising signs in proximity to traffic control devices

The location of advertising signs or devices in close proximity to traffic control devices may result in the advertising sign obscuring a traffic sign or otherwise detracting from the traffic sign's effectiveness. Traffic control devices place demands on a driver's attention and are often located at sites to warn of specific hazards or to control hazardous traffic movements. Distractions caused by advertising signs may result in road safety problems. To help avoid safety issues, advertising signs should not be located within 100m and 200m in urban and rural areas respectively of:

- intersections
- permanent regulatory or warning signs
- curves (with chevron signing)
- pedestrian crossings.

5.6 Sign supports

Advertising signs or devices may create a roadside hazard if they are mounted on rigid (non-frangible) supports or vehicles and they are located (or are proposed to be located):

- where they are likely to be struck by a vehicle of an errant driver
- on a footpath or alongside the road in a position where they are in the normal paths of pedestrians – blind or partially sighted pedestrians are particularly vulnerable to poorly located signs on footpaths.

This problem (other than portable roadside advertising) can be dealt with by:

- maintaining adequate lateral clearance between the through traffic lanes and the advertising device
- installing devices that are lightweight or frangible in nature.

Signs not requiring frangible supports

The Road Safety Manufacturers Association (RSMA) compliance standard for traffic signs 2008 provides guidance and specifications for the design of steel, timber and aluminium supports that do not require frangible supports.

For further information refer to Part 1 of the TCD manual, the NZTA *Performance based specification for traffic signs* (TNZ P/24), or the RSMA website.

Signs with frangible supports

The RSMA compliance standard for traffic signs 2008 provides guidance and specifications for the design of frangible supports including reference to:

- specific designs to AS/NZS1170
- breakaway supports that conform to *AASHTO 2001 Standard specifications for structural supports for highway signs, luminaries and traffic signals*
- alternative means of compliance.

For further information refer to Part 1 of the TCD manual, the Agency's *Performance based specification for traffic signs* (TNZ P/24), or the RSMA website.

5.7 Number of signs (sign density)

The effectiveness of roadside advertising, as well as road safety and the environment, may be compromised if there are too many advertising displays on the roadside.

Directory boards

For on-site signs, the overall effectiveness of signing can be optimised by installing a single well-designed and located advertising sign per business premise. Similarly, at sites with a number of businesses in close proximity or sharing the same driveway, it is more effective and appropriate from a road safety and urban design perspective for them to share a single directory board rather than each business installing their own sign.

Off-site advertising signs

To avoid excessive clutter of roadside advertising signs, it is recommended that TAs/RCAs restrict the installation of off-site advertising. Such an approach is a practical method of controlling the proliferation of roadside advertising. It is noted however that provided controls are adequate to ensure orderly and legible displays, there is no reason why an off-site advertising sign should have more of an adverse effect than a similar on-site sign. Indeed, in some situations in rural areas, off-site advertising in advance of or in close proximity to a site may serve its purpose more safely and effectively than on-site advertising.



Figure 5.2 Off site advertising signs grouped together to avoid excessive clutter

Consenting authorities should cater for such situations in areas with speed limits of 70 km/h or more and/or develop policies in relation to provision of official signing for tourist and service activities. (See Part 2 of the TCD manual for further information concerning tourist and service signs).

In situations where off-site advertising signs that are visible from a road are permitted, they should be located in excess of the minimum spacing indicated in table 3.

6 Sign design

6.1 Sign legibility

In order for any advertisement to communicate a message it must first be seen by the audience for which it is intended. From a moving vehicle, there are limits to the detail that can be seen, read, comprehended and acted upon. Accordingly, advertising signs are only effective if they are legible in the circumstances in which they are seen. If the location and context of a sign are satisfactory, it is generally the detailed aspects of a sign such as its content, the colour, letter size and letter style that determine its legibility.

Travel speeds need to be considered in designing the message on an advertising sign:

- As travel speed increases, foreground details begin to fade so signs need to be legible from a greater distance. For further detail on this effect (refer to Figure 5.1).
- At 100 km/h a driver can only handle and comprehend two events at once, such as the driver talking to a passenger while simultaneously trying to negotiate travelling through an intersection. If a driver is to comprehend an advertising sign in addition to two or more other events they will have to slow down to read the sign otherwise the likelihood of the sign message being seen is reduced. As identified in section 5, such behaviour is not appropriate or safe.

A major factor when designing signs is the need to note that people have a greater capacity for assimilating pictorial material than text. As such, there is a strong argument for using pictures or symbols on a sign rather than written words.

The size and type of font, the amount of text and colour all have an effect on the legibility. See section 6.5 for further details.

6.2 Sign message

The effectiveness of an advertising sign and the message being imparted is heavily dependant upon the simplicity of the sign. Refining the message to contain only the essential information is a key to successful message presentation. Generally drivers' capabilities are limited to:

- picking one item of essential information from approximately ten items (syllables, symbols, and abbreviations) on a sign
- assimilating up to six items of information on a sign where all are essential or of equal importance.



Figure 6.1 Complicated advertising sign that is difficult to read

In general, advertising signs can inform road users of the location of a commercial enterprise and may assist the movement of traffic with good directions to popular commercial centres providing the message is not confused with a traffic instruction.

Advertising signs must not:

- imitate traffic signs and any traffic control device
- give instructions to motorists that conflict with any traffic sign or traffic control device.

In addition, advertising signs should not:

- compete with existing direction signs
- in the case of a sign inviting road users to turn, be located close enough to the turning point that road users have insufficient time to read the sign, indicate and turn safely.



Figure 6.2 Inappropriate advertising signs that looks like traffic signals

Advertising signs and messages should also comply with the Code of Ethics provided by the Advertising Standards Authority (refer section 3.2).

6.3 Sign style

In addition to conveying written and symbolic information, an advertising sign can help the viewer identify its subject by its overall character and style. Careful use of materials, shape, lettering style and colour can contribute to quick and easy communication of the information provided by the words and symbols.

Graphics on roadside advertising signs should meet four criteria:

- express the proprietors' identity
- be appropriate to the type of activity to which the sign relates
- be compatible with the visual character of the surrounding area
- be legible in the circumstances in which they are seen.

A recognisable advertising sign style is a means of establishing a corporate identity - particularly for an advertiser with multiple signs. Such signs may make their message clear at a glance and may make a positive contribution to the visual environment.



Figure 6.3 Corporate identification

6.3.1 Colour of advertising signs and devices

Careful use of colour can be an effective way of improving the legibility of a sign. However, an advertising sign or device should not be displayed or constructed where visible from a roadway if it:

- is coloured red, green, orange, white or yellow in combinations of colours or shapes which may be mistaken for a traffic control device
- has red, green, orange, white or yellow in isolation or in combinations of colours and in a location where it is likely to form the foreground or background to or appear alongside a traffic control device of similar colour when viewed by approaching motorists

- contains large areas of red, green or orange display on illuminated signs which at night are likely to cause confusion with traffic control signals or tail lights of vehicles.

6.3.2 Illumination and glare from advertising

There is a need to control the brightness (when internally or externally illuminated) of advertising as installations that are too bright may impair the vision of drivers. This is mainly due to the phenomenon of phototropism, which is the movement of the eye to fixate on bright points in the field of view. To avoid the above problems, any advertising signs or devices which are internally or externally illuminated should:

- comply with the maximum luminance's given in Table 6.1
- have all floodlights or concealed lighting directed solely on to the advertisement and its surrounds
- have any light source shielded so that glare does not extend beyond the advertisement
- with the exception of neon signs, have no light source visible to passing motorists with a light output greater than that of a 65 W incandescent bulb.



Figure 6.4 Illuminated stacked sign

Table 6.1 – Maximum luminance (cd/m²) of illuminated advertising devices (Source: UK ILE)

Illuminated area (m ²)	Areas with street lighting	Areas without street lighting
up to 0.5	2000	1000
0.5 to 2.0	1600	800
2.0 to 5.0	1200	600
5.0 to 10.0	1000	600
Over 10.0	800	400

Further technical information on the brightness and luminance of signs can be found in the following publication: *Brightness of illuminated advertisements*, The Institution of Lighting Engineers.

6.3.3 Animated, flashing and variable message signs

When considering animated, flashing, and variable message signs for advertising, care is needed with regards to location and visibility distraction to motorists. A report by Johnston and Cole¹ reported that 'it is well known that displays of a novel, intriguing, sensuous, colourful or dynamic (moving) nature... provide a more powerful distraction than familiar or static displays.'

The NZTA and many TAs have banned or have specific, stringent controls on the use of animated, flashing or variable roadside advertising signs.

¹ *Investigations of distraction by irrelevant information* Johnston, A W and Cole, B L.

Animated or flashing signs should not be used as roadside advertising if they have any of the following characteristics:

- They incorporate a revolving light of any colour. Such devices can also be mistaken for an emergency vehicle, road works, etc. Note that the use of flashing beacons is also prohibited by clause 8.5 of the Road User Rule.
- They rotate as a whole about any axis other than a vertical one.
- The message is more complex than a single word, logo or symbol displayed in any direction at one time.
- The operating speed of the passing traffic is 70 km/h or greater.

Variable message signs, which include moving panel signs, are animated signs which have considerable potential to distract motorists. Therefore, each installation or proposed installation needs to be reviewed to ensure that possible distractive effects are minimised. In particular, in addition to the above situations, proposals to install variable message signs should be carefully assessed where:

- they are located close to an intersection, merging or diverging traffic sites or other sites where demands on motorists' concentration are high
- each separate display is not static from first appearance to replacement
- the time to change from one display to the next is greater than two seconds
- the minimum time for any separate display is less than five seconds.



Figure 6.5 Inappropriate use of variable message sign as it is located at busy city intersection

For general design principles and specifications for variable message signs refer to Part 1 of the TCD manual as well as the NZTA *Fixed variable message sign design guide*.

Further information on the use of variable message signs as part of temporary traffic management is available in Part 8 of the TCD manual (CoPTTM).

6.3.4 Inappropriate advertising sign styles

Inappropriate advertising sign styles include signs that:

- could be mistaken for or confused with a traffic sign
- imitate a traffic sign or traffic control device
- move or give the appearance of motion, eg by use of sequentially flashing lights
- include lights or light sources which flash, revolve, move or vary in intensity
- are variable message signs (unless they satisfy the requirements in section 6.4.3).

Advertising signs with these characteristics are unlikely to be acceptable and may not be considered legal.

6.4 Sign layout

Having established the message content and style of the advertising sign, the advertising sign layout should be considered. The most important factors include:

- letter size
- letter style
- letter hierarchy
- the background colour on the sign
- the contrast between the message and the background.

6.4.1 Letter size

The size of the lettering for any words on an advertising sign should be increased as the speed of passing traffic increases. As motorists travel at higher speeds, they have less time to read and respond to the sign's message. On this basis, any wording should have minimum letter sizes conforming to those in table 5.

Table 6.2 – Minimum recommended letter sizes on roadside advertising signs

Posted speed limit (km/h)	Letter height (mm)		
	Main message	Property name	Secondary message
50	150	100	75
60	175	125	90
70	200	150	100
80	250	175	125
100	300	200	150

Notes:

- This is guidance for advertising adjacent to state highways, but can be applied to local roads as well.
- Lettering or symbols on signs that are permitted within the state highway road reserve should be at least 120 mm in height for < 70 km/h roads and 160 mm in height for ≥ 70km/h roads.

6.4.2 Letter style

Some typefaces are harder to read than others. Words made up of condensed letters which are all capitals are much harder to read than words with both upper and lower case letters. The spacing between letters and between words, the thickness of the letters and variations in the thickness of letters also affect legibility. Among the easiest fonts to read are Helvetica and Transport Medium which are commonly used on traffic signs for this reason. They are characterised by lettering that is visually simple, of consistent thickness and lacking decoration. Examples of good styles and those that are undesirable are shown in Table 6.3.

Table 6 – Examples of good styles and those that are undesirable for advertising signs

Good examples	Undesirable examples
Helvetica	Linoscript
Universe	Arcadia
Optima	Vivante
Paddington	Marriage
Tabasco	Atlas
Frankfurter	Robotic Monkey

6.4.3 Letter hierarchy

Legibility is increased when the important parts of the message are given emphasis through increased letter size.



Figure 6.6 Lettering hierarchy examples. All examples show the most important message in larger font

6.4.4 Sign background

Legibility is also aided by having a clear background on the sign. Clear backgrounds help people to isolate the individual message (refer Figure 6.7). A general rule is that the message on a sign should take up no more than the following proportions of the total area of the sign:

- 40% in commercial or industrial areas where there are other competing signs
- 60% in rural or residential areas with few other signs.



Figure 6.7 Sign examples showing clear backgrounds which enhances the legibility of the message

6.4.5 Contrast between message and background

The contrast between the message and the background on the sign also affects legibility. The message should stand out from the background colour with colours of a similar tone tending to merge into one another, particularly from a distance.



Figure 6.8 Sign background examples. The first sign shows good contrast, while the other two photos indicate poor contrast and legibility as the colours of the billboard and message blend into the rest of the sign and the buildings behind it.

6.4.6 Sign reverse

There are no requirements for the type of information required or not allowed on the panel reverse. However any information still needs to meet any advertising and traffic sign standards if it is viewed by road users and comply with the contents of this document.

6.5 Sign material

Examples of different materials used for signs and supports include:

- metal
- timber
- paper
- plastic
- textile.

The material from which an advertising sign is constructed will affect the style of the sign and its durability. The materials should reinforce the message by contrast or by integration. In an area where there are several signs, the goal should be one of consistent quality rather than uniform materials or appearances, ie the signs do not all have to have the same style, but a similar standard of construction and presentation is preferred.

The most important factors to consider when selecting materials for a sign are:

- appropriateness to the style
- sheeting material and type
- relationship with the surroundings
- durability
- costs (capital and maintenance).

The materials chosen will convey their own message, which should reinforce the intent of the sign's style. For example a bright neon sign would not be appropriate to advertise a heritage building.

6.5.1 Reflectivity and fluorescence

As indicated in Section 3, the TCD Rule states advertising signs should not be reflective or fluorescent as stated in the TCD rule.

Most RCAs have similar requirements in their bylaws, guidelines and district plans.

6.5.2 Relationship with the surroundings

The materials should be chosen for the way in which they relate to the setting. This can be done by integration or by contrast. Integrative signs have forms and colours that are appropriate for their contexts. A contrasting approach aims to emphasise the sign by giving it a prominent location or colours and forms that contrast with the surrounding. It is not essential to use only rustic materials in rural areas and more up-market materials in urban areas to achieve an effective result.

6.5.3 Sign durability

It makes economic sense to match the type of materials used with the intended life span of the sign, eg corrugated plastic is ideal for short term signs such as political hoardings. For long term signs it is also important to match the materials used for the different parts of the sign including the message and the background. If colours fade too quickly the sign will become illegible.

6.5.4 Sign costs and maintenance

It is important to match the initial capital input to the intended life of the sign particularly to avoid higher maintenance or replacement costs in the future.

Regular maintenance, including keeping advertising signs clean and legible is considered necessary for them to remain effective in providing messages to road users. For all other general maintenance of traffic signs reference Part 1 of the TCD manual.

6.6 Amenity and urban design

The design of advertising signs can have a significant affect on the amenity of the environment in which they are located. Many TA's have requirements in their guidelines, bylaws and district plans to ensure the visual amenity of the environment is not compromised by advertising signs located within it.

7 References

The following are references that appear first in this Part. It is intended these will be added to an accumulated list of references for the TCD manual the current version of which can be found at <http://www.landtransport.govt.nz/tcd-manual/references.html>

Advertising Code of Ethics NZ Advertising Standards Authority (http://www.asa.co.nz/code_ethics.php)

Brightness of illuminated advertisements. Technical Report Number 5 (Second Edition) Institution of Light Engineers, United Kingdom, 1991

Electoral (Advertisements of a Specified Kind) Regulations 2005 New Zealand Government

Electoral Act 1993 New Zealand Government

Fixed Variable Message Sign Design Manual NZ Transport Agency

Forest and Rural Fires Act 1997 New Zealand Government

Forest and Rural Fires Regulations 2005 New Zealand Government

Heavy Vehicle Visibility Code Land Transport Safety Authority

Investigations of distraction by irrelevant information Johnston, A W and Cole, B L, Australian Road Research, Volume 6, No 3, Australian Road Research Board, 1976

NZS1170 Structural design actions – comprised of parts 0, 1, 2, 3 and 5 and associated Supplements and Amendments – 2002 to 2004

Policy Planning Manual NZ Transport Agency

Standard Specifications for Structural Supports for Highway Signs, Luminaries and Traffic Signals, Association of American State Highway Officials (AASHTO) 2001

State Highway Control Manual NZ Transport Agency

Transit New Zealand (Signs on State Highways) Bylaw 2003/13: Bylaw regulating Signs on State Highways Published in the *NZ Gazette*, 13 November 2003, No 154, page 4316.

([http://www.dia.govt.nz/Pubforms.NSF/NZGZT/NZGazette154Nov03.pdf/\\$file/NZGazette154Nov03.pdf](http://www.dia.govt.nz/Pubforms.NSF/NZGZT/NZGazette154Nov03.pdf/$file/NZGazette154Nov03.pdf))