

WELLINGTON, NEW ZEALAND

PURSUANT to sections 152 and 155(a) and (b) of the Land Transport Act 1998

I, Steven Joyce, Minister of Transport,

HEREBY make the following ordinary Rule:

Land Transport Rule: Heavy Vehicles Amendment

SIGNED AT Wellington

This *22nd* day of *August* 2011

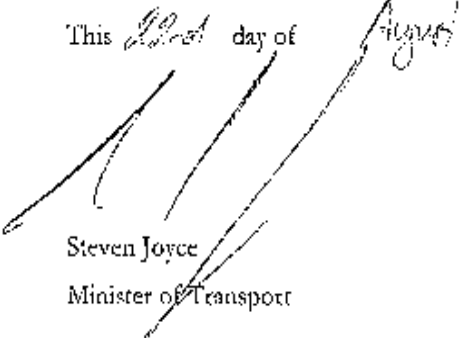
Steven Joyce
Minister of Transport

Land Transport Rule
Heavy Vehicles Amendment (No 2) 2011
Rule 31002/5

ISSN 1173-1559

Published by:

NZ Transport Agency
Private Bag 6995
Wellington 6141
New Zealand

Email: info@nzta.govt.nz

Freephone: 0800 699 000

Printed and distributed by:



Wickliffe Limited
PO Box 932, Dunedin
New Zealand

Land Transport Rule
Heavy Vehicles Amendment (No 2)
2011

Rule 31002/5

Contents

Objective of the Rule		vii
Extent of consultation		vii
<u>Part 1</u>	<u>Rule requirements</u>	
Section 1	Application	1
1.1	Title	1
1.2	Date when Rule comes into force	1
1.3	Scope of Rule	1
Section 2	Amendments to Rule requirements	1
2.1	Vehicle body and equipment attachment	1
2.2	Skid plates and kingpins	1
Section 3	Amendment to Schedules	1
3.1	New Schedule inserted	1
<u>Part 2</u>	<u>Schedule</u>	3
	New <i>Schedule 4</i> Bolster Attachment Code	3

Objective of the Rule

Land Transport Rule: Heavy Vehicles Amendment (No 2) 2011 amends *Land Transport Rule: Heavy Vehicles 2004* ('the Rule'). This Rule sets out requirements and standards for heavy vehicle safety. It applies to vehicles with a gross vehicle mass of more than 3500 kg.

The objective of the amendment Rule is:

- to insert a new revision of the Bolster Attachment Code; and
- to delete a Rule provision that has become redundant as a result of the 1 April 2011 Rule amendment that removed the requirement to test kingpins.

Extent of consultation

For the purposes of consultation, amendments proposed to *Land Transport Rule: Heavy Vehicles 2004* and 10 other Land Transport Rules were combined into a single draft Rule, *Land Transport Rule: Omnibus Amendment 2011* (the draft Omnibus Amendment Rule).

On 1 June 2011, the NZ Transport Agency (NZTA) sent details of the amendment proposals by letter or email to approximately 2200 groups and individuals who had registered an interest in the Rules to be amended. The draft Omnibus Amendment Rule was made available through the NZTA Contact Centre and, together with Questions and Answers, was also made available on the NZTA's website. The availability of the draft for comment was publicised in the daily newspapers in Auckland, Hamilton, Wellington, Christchurch and Dunedin and in the *New Zealand Gazette*. The NZTA received 17

submissions on the draft Omnibus Amendment Rule, of which 10 commented on the proposed amendments to the Rule.

Following consultation, the provisions in the draft Omnibus Amendment Rule were split into 11 separate amendment Rules, including this Rule. The submissions that were received were taken into account in finalising this amendment Rule before it was submitted to the Minister of Transport for signing.

Part 1 **Rule requirements**
Section 1 **Application**

1.1 **Title**

This Rule is *Land Transport Rule: Heavy Vehicles Amendment (No 2) 2011*.

1.2 **Date when Rule comes into force**

This Rule comes into force on 1 October 2011.

1.3 **Scope of Rule**

This Rule amends *Land Transport Rule: Heavy Vehicles 2004*.

Section 2 **Amendments to Rule requirements**

2.1 **Vehicle body and equipment attachment**

Subclause 3.2(3) is amended by inserting “or Schedule 4” after “Schedule 2”.

2.2 **Skid plates and kingpins**

Subclause 4.8(6) is amended by:

- (a) inserting “by means of visual inspection.” after “detected”; and
- (b) deleting *paragraphs (a) and (b)*.

Section 3 Amendment to Schedules

3.1 New Schedule inserted

Part 3 Schedules is amended by inserting the Schedule set out in the *Schedule* of this Rule as *Schedule 4*.

Part 2 Schedule

New *Schedule 4* inserted

“Schedule 4 Bolster Attachment Code

(Revision 2 November 2010)

1 INTRODUCTION

1.1 Objective

The bolster attachment system shall be designed as a total system to ensure that all loads imposed, as specified below, are reacted back to the vehicle chassis.

In particular, the Certifying Engineer shall consider all connection systems to the chassis including, but not limited to: bolts and bolt groups, twistlocks, lashings, welded fabrications, load cells, bolster pivot pins, resilient mountings and intermediate structural members. The designer shall also consider the loads the design imposes on the chassis and the bolster.

1.2 Certification life

It is expected that Design Certificates issued according to this Code should remain valid for a minimum of three years and a maximum of ten years. Samples of acceptable forms for compliance certificates are shown in the Appendix to this code.

It is permissible to use components within the bolster attachment system which may have design or service lives shorter than the life specified within the Design Certificate provided that:-

- (a) The short life components are identified in detail in the Design Certificate.

and

- (b) The detail in the Design Certificate, shall have a table showing component replacement dates.

and

- (c) The Design Certificate table shall be signed off by a responsible person confirming that periodic replacement of such components has been properly carried out.

Bolster attachments may be recertified at the end of their certified life where justified on the basis of assessment by a Certifying Engineer. Any repair or modification work required to extend certified life must comply with this Code of Practice.

1.3 Proprietary components

Any proprietary components used for the purpose of bolster attachment shall be rated, approved and certified by their original manufacturer, or Certifying Engineer, as being fit for that purpose according to the loading provisions of this Code.

1.4 Repairs and modifications

Repairs and modifications to the bolster attachments should be undertaken by the original manufacturer or their authorised agent.

All modifications shall be recertified by a Certifying Engineer as in 2.8.

1.5 Vehicle and bolster identification

Individual bolsters shall be stamped, indelibly labelled or marked to clearly identify their serial number.

Individual bolster mounts shall be stamped, indelibly labelled or marked to clearly identify their serial number.

At least one tag per vehicle shall be fitted identifying the bolsters, bolster attachments, bolster rating, the certifier, the manufacturer, vehicle, and expiry date compatible with the requirements of NZS 5444.

2 DEFINITIONS

2.1 Vehicle payload

Vehicle payload shall equal the manufacturer's rated GVM minus tare, and shall not be distributed to exceed the rating on any individual component of the vehicle or vehicles.

Note: The equipment manufacturer has the right to nominate a maximum GVM less than the original vehicle manufacturer's GVM or any NZTA limitations.

2.2 Rated Bolster Load; L_R

The Rated Bolster Load is the maximum payload that the bolster may carry, and shall be the greater of:

- (a) The known load calculated as a share of the total payload for predictable configurations

or

- (b) where bolsters are loaded in a nominally equal manner or are loaded indeterminately; the bolster load shall be the total payload divided by the number of bolsters.

For different loading cases there may be different numbers of bolsters capable of resisting each load case specified. The bolster load shall be found by dividing by the number of bolsters resisting each loading case.

2.3 Bolster Assembly Mass; D

Bolster Assembly Mass, D shall be taken as the mass of the bolster and any other structure or securing hardware attached with the bolster.

2.4 Design Bolster Load: Static: L_{DS} Dynamic: L_{DF}

The Rated Bolster load calculated in 2.2 above shall be increased to allow for maldistribution within the log payload by a maldistribution of payload factor, M, for static loadings only, where

$M = 1.2$ for all static loads on longs bolsters

$M = 1.2$ longitudinal loading calculations

$M = 1.4$ otherwise

So; $L_{DS} = M \times L_R + D$ and $L_{DF} = L_R + D$

2.5 Loads

Where the term 'g' is used this shall be taken as $g = 9.81 \text{ m/s}^2$. All other variables or quantities shall be taken as measured in SI units unless specified.

Dynamic loads expressed in this Code are given as (Fatigue) Dynamic Load Ranges from which Fatigue Stress Ranges can be calculated and compared with allowable stress ranges.

Static loads are expressed as peak static loads in either direction (ie: up/down, left/right, tension/compression) from which peak static stresses can be calculated and compared with allowable stress levels. All loads shall be applied independently of any other design loads (ie: none shall be considered simultaneous).

Also, fatigue cycle counts in each mode of loading shall be considered independent of every other mode.

The load cycles are therefore to be counted as though no other mode of loading exists.

2.6 General design requirements

Design shall be to AS 3990 for both static and dynamic loadings or alternatively to AS 3990 for static loading and to BS 5400 PT10 or BS7608 for dynamic loading.

Guidance on allowable stresses for materials other than those permitted under these standards should be sought from reputable internationally recognised Standards.

For the dynamic condition the stress at 2×10^6 cycles is to be used (in AS3990, loading condition 3 applies), based on an expected 10-year life. Where applicable a probability of failure of 2.3% should be used. In certain cases, a higher probability of failure could be acceptable, for example, where fatigue cracking would not have serious consequences and where a crack could be easily located and repaired. It is permissible to use shorter design life or components with shorter design life provided that any such component is identified as per Section 1.2.

Where any component is likely to be damaged, worn or distorted during normal operational wear and tear, the Engineer shall select a fatigue stress level, class or category appropriate to the probable damaged condition. The Engineer shall not base allowable stress levels upon the as-new undamaged condition.

At the discretion of the Certifying Engineer a maximum service life may be specified on the Design Certificate.

2.7 Load Centre

The Load Centre shall be assumed to exist at the geometric centroid of the area bounded by the bolster bed, inner faces of the stanchions and a horizontal line across the tips of the stanchions or extension pins, if fitted.

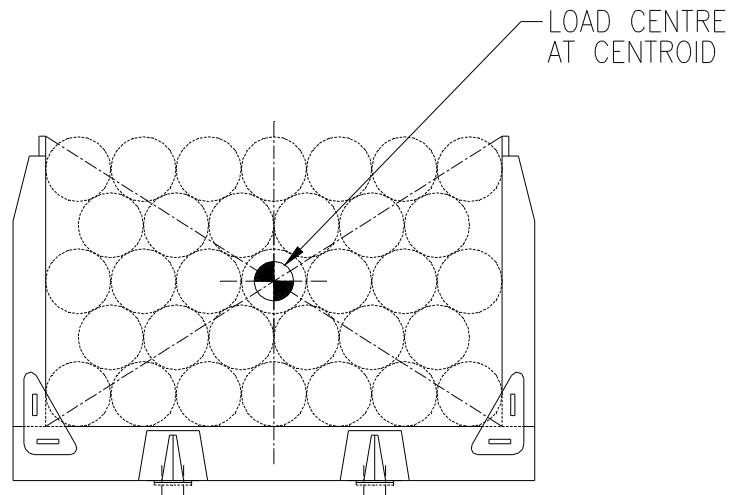

Figure 1 Determination of the load centre position

2.8 Certifying Engineer

The Certifying Engineer (HVEL category) shall be approved by the New Zealand Transport Agency on the recommendation of the Log Transport Safety Council.

2.9 Longs Bolster

Longs bolsters are designed to support logs suspended between separate towing and towed vehicles. Their mounting system allows for articulation between the vehicles.

2.10 Shorts Bolster

For the purposes of this Code, a shorts bolster is one designed to support, in conjunction with one or more other bolsters, a log packet carried on a single vehicle.

2.11 Convertible (longs/shorts) vehicle

A vehicle capable of being used in both longs and shorts operation. The bolster mounting system is able to be rapidly reconfigured to suit either mode.

3 VERTICAL LOADS

3.1 Application

The static and dynamic vertical loads shall be applied as a uniformly distributed load across the top of the bolster bed, equal in total to the values specified below.

The weight of the bolster and attachments may be ignored for vertical loadings.

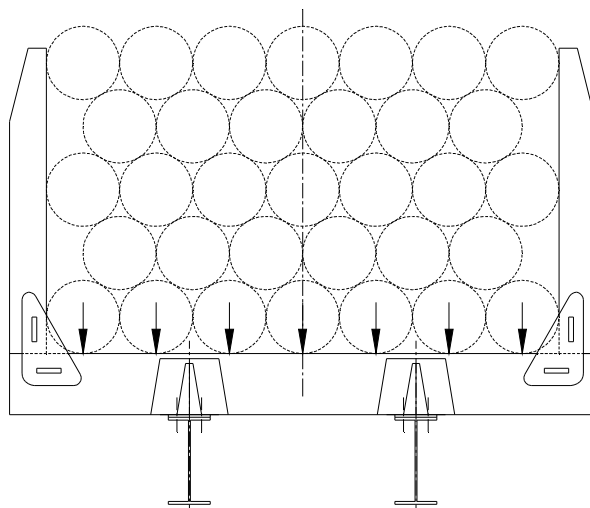

Figure 2 Application of vertical loads

3.2 Static Vertical Load; P_v

$$\text{Downwards: } P_v = L_{DS} \times 2.5 \text{ g}$$

$$\text{Upwards: } P_v = L_{DS} \times 0.5 \text{ g}$$

3.3 Dynamic Vertical Load Range; Q_v

$$Q_v = L_{DF} \times 2.0 \text{ g (ie } \pm 1.0 \text{ g)}$$

4 TRANSVERSE LOADS

4.1 Application

The static and dynamic transverse loads shall be applied as forces at the load centre as in *Figure 3* below.

Weight due to gravity @1 g may be superimposed as a uniformly distributed load (UDL) across the bolster to help resist transverse loadings.

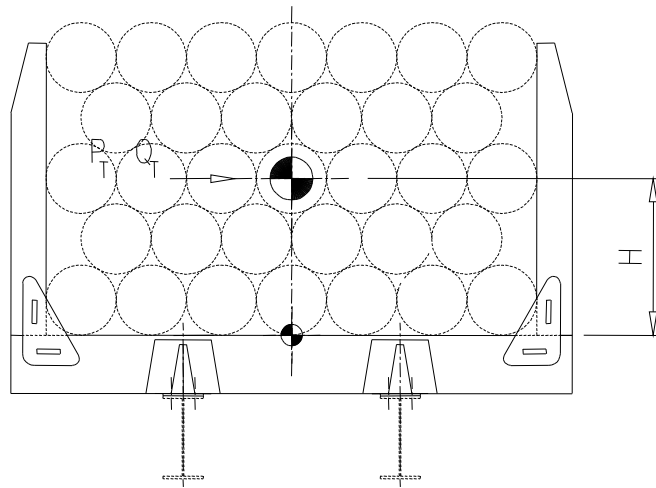

Figure 3. Application of transverse loads

4.2 Static Transverse Load; P_T (*applies at the Load Centre*)

$$P_T = L_{DS} \times \pm 0.5 \text{ g}$$

4.3 Dynamic Transverse Load; Q_T (*applies at the Load Centre*)

$$Q_T = L_{DF} \times 1.7 \text{ g (ie. } \pm 0.85 \text{ g)}$$

5 LONGITUDINAL LOADS

5.1 Application

Longitudinal loading shall be checked in each of four cases

- 2 dynamic Q_{L1} , Q_{L2}

- 2 static PLF, PLR

as detailed below and weight due to gravity @1g may be superimposed as a UDL across the bolster to help resist longitudinal loadings.

5.2 Static Longitudinal Loads P_{LF} , P_{LR}

Forwards: $P_{LF} = L_{DS} \times 1g$

Applied 300 mm above bolster bed height.

Rearwards: $P_{LR} = L_{DS} \times 0.5g$

Applied at the bolster bed height.

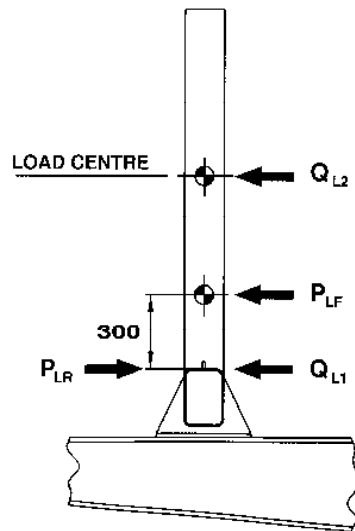

Figure 4 Application of longitudinal loads

5.3 Dynamic Longitudinal Loads; Q_{L1} ; Q_{L2}

$Q_{L1} = L_{DF} \times 2.0g$ (ie. $\pm 1.0g$)

Applied at Bolster Bed Height

$Q_{L2} = L_{DF} \times 0.25g$ (ie. $\pm 0.125g$)

Applied at Load Centre

6 SPECIAL TYPES OF BOLSTER MOUNTINGS

The design loads specified in sections 3.0, 4.0 and 5.0 were specifically measured as being applicable to bolsters, of high torsional and bending stiffness, rigidly mounted onto a relatively flexible chassis structure.

A wide variety of configurations exists, and may expand in the future, where the connection between the bolster unit and chassis has some measure of compliance in torsion and/or linear location.

In recognition of the fact that:

- (a) Not every configuration can be effectively tested and
- (b) The impact and torsion induced loadings on such arrangements are significantly reduced, the Dynamic loadings Q_V , Q_T and Q_{L1} and Q_{L2} (as defined in 3.0, 4.0 and 5.0) shall be reduced as follows:
 - (i) for all bolts and fasteners the dynamic loads shall be reduced by 50%
 - (ii) for welds the dynamic loads may be taken as being sufficiently low as not to require detailed fatigue design. However, dynamic loads do exist and good fatigue detail design practice should be followed
 - (iii) for all other parts of the restraint system the dynamic loads may be taken as zero. Good fatigue detail design practice should be followed.

The reduced dynamic loadings shall only apply to the following types of bolster attachment as defined below. Physical testing may be required to confirm compliance with these definitions.

6.1 Torsionally Independent Bolsters

Typically bolster types relying upon either gravity or resiliently restrained bolts to resist the longitudinal loads. The main connection to the chassis allows torsional displacement of the chassis rails without loading of the bolster bed through the attachment.

A minimum total of 2 degrees angular displacement between the bolster and each chassis rail in the longitudinal vertical plane (see *Figure 5*), with an increase in contact loads not exceeding 10 kNm/degree between bolster and chassis members, shall be achieved.

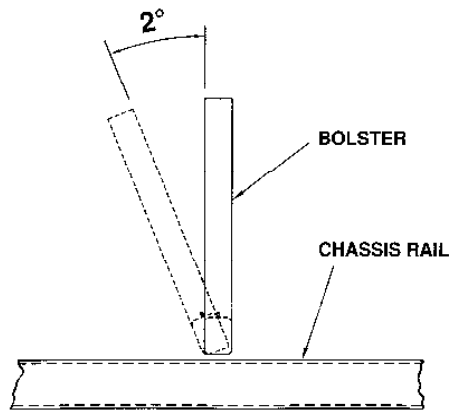

Figure 5. Angular displacement requirement for torsionally independent bolster attachments (not to scale)

6.2 Sliding Bolsters

Bolsters mounted on sliding attachments where sufficient clearance exists to meet a minimum ± 1 degrees angular displacement (see Figure 6), with an increase in contact loads not exceeding 20 kNm/degree between bolster and chassis members.

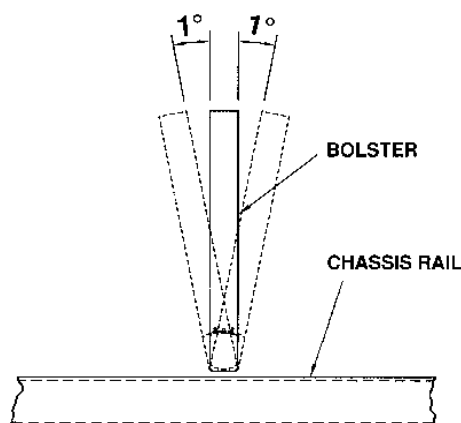

Figure 6 Angular displacement requirement for sliding & resilient bolster attachments (not to scale)

6.3 Resiliently Mounted Bolsters

Resiliently mounted bolsters are those for which the incremental rotational stiffness does not exceed 20 kNm/degree (per attachment) for

an angular displacement of ± 1 degree about the transverse axis (see *Figure 6*).

Typically these bolsters will be elastomeric or metal spring mounted with overriding solid connections to prevent excessive displacement.

The term “incremental stiffness” is intended to allow for preloading of resilient mounts such that static deflections under rated loads can be minimized, whilst maintaining relatively low natural frequencies at the loaded condition.

6.4 Longs and Convertible Units

Bolster mounting systems or individual bolster mounts on vehicles designed for longs or longs/shorts (convertible) operation and which are new into service after 31/3/2005 must comply with either section 6.4.1 or 6.4.2 below.

6.4.1 Type Approval

Bolster attachment systems or individual bolster mounts on longs or convertible logging vehicles may be considered to comply with this Code, provided that the manufacturer (who must also be an HVML manufacturing certifier) or an HVEL certifying engineer has evidence available for audit by the New Zealand Transport Agency that the particular design of the bolster attachments has successfully completed, on a single vehicle, 250,000 kilometres of service without any indication of cracking due to fatigue or other significant failure.

For each vehicle incorporating this design, at least one “Statement of Compliance with Type Approved Design” (see Appendix) must be signed and referred to in the Heavy Vehicle Compliance Certificate (LT400) which is issued at the time of first presentation of the vehicle for registration. Expiry date of certification is to be within the period stated in section 1.2.

6.4.2 Certification by calculation

In general, the loads specified in sections 3, 4, 5 and 6 of this Code shall be applied, with the following provisions and exceptions:

The longs bolster shall be able to rotate fore and aft about its transverse axis by at least $\pm 5^\circ$ where the incremental stiffness of the bolster attachment does not exceed 20 kNm/degree of angular displacement (see *Figure 7*).

Side to side rotation of the longs bolster about the longitudinal axis of the vehicle shall be limited to avoid instability.

Provision shall be made for the longs bolster to rotate about its vertical axis. This may be done utilising a standard trailer dolly ballrace turntable or slewring. The Engineer shall justify the rating of the ballrace turntable or slewring by applying the turntable manufacturer's requirements for the longs logging application using the static loadings specified in sections 3, 4 and 5 and the reduced dynamic loadings specified in 6.0.

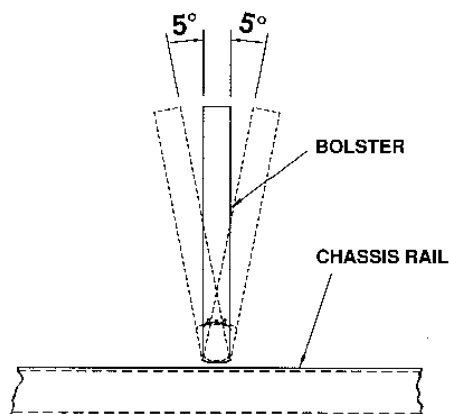

Figure 7 Angular displacement requirement for longs bolster attachments (not to scale)

In the absence of these requirements, the design bolster load, L_{DF} shall not exceed 1.25 times the manufacturer's static vertical rating for the turntable or slewring when used on a trailer dolly.

The ballrace turntable or slewring shall be supported over at least 50% of the circumferential area of both top and bottom rings, with detailed design of the bolting being carried out by the Engineer.

Where ballrace turntables or slewrings designed for trailer dollies are not used, the loads specified in sections 3, 4, 5 and 6 of this Code shall be applied.

7 DESIGN OF BOLTED CONNECTIONS

For some detail arrangements of bolster attachments, some bolted connections may rely on the provision and maintenance of pre-tensioned axial loads to avoid premature failure of the bolt(s) or joint. In such critical applications the manufacturer and/or Certifying Engineer shall specify and ensure the provision of:

- (a) correct bolt size, grade, type, thread form
- (b) installation procedure (e.g. torques, tightening procedures)

- (c) retention devices or system to retain nuts, studs, unless deemed by the designer to be unnecessary for the design
- (d) data plate permanently fixed to the vehicle close to the bolts and detailing information a, b and c above.

Bolt design shall be undertaken by the following means:

- (a) by the manufacturer of proprietary specialised components (e.g. load cell manufacturer) by design calculation and/or testing to the loading provisions of this Code, where applicable;

otherwise

- (b) bolts subject to dynamic loads predominantly in the axial direction shall be designed to BS 7608

and

- (c) bolts subject predominantly to dynamic shear loads shall be designed to AS3 990

and

- (d) where bolts have been fitted in holes with clearance on diameter of less than 0.1 mm, then, for the purposes of this Code, the joint needs to be designed to avoid slip in accordance with AS 3990 Appendix F section F3 in the dynamic load case only. The Engineer shall establish the appropriate slip factor to use for the bolt torques specified. The bolts shall still be separately designed for the full static loads, but in this case limited slip is permissible.

and

- (e) non metric bolts, to a suitable recognised standard, for example, S.A.E., may be substituted for metric bolts referred to in AS 3990 and BS 7608 provided they meet the loadings imposed in terms of this Code.

8 WELDING CONSIDERATIONS

All welding shall comply with AS/NZS 1554.1 or for quenched and tempered steels AS/NZS 1554.4. The required weld categories (GP, SP or FP) shall be stated on the drawings.

9 SECONDARY ATTACHMENT DEVICES

Where an existing primary attachment does not meet the requirements of this Code it is permissible to fit a secondary independent bolster

attachment system to ensure restraint of the bolster should the primary system fail. The secondary attachment device is permissible for bolsters manufactured and fitted to vehicles before the introduction of this Code.

The secondary system shall:

- (a) be capable of meeting the load and stress requirements of clauses 3.2, 4.2, 5.2 and clause 2.6 for static loadings only
- and
- (b) be used only to provide emergency restraint to the bolster(s) until the primary system is immediately and permanently repaired
- and
- (c) restraining the bolster in position under load, not exceeding 10 mm linear displacement in any direction, or ± 5 degrees angular displacement, from the normal unloaded bolster position.

APPENDIX

Sample forms of NZTA approved acceptable design certificates.

Engineers or Company Letterhead - including name, physical address plus postal address, phone, fax etc

Bolster Attachment Code:

Certificate of Installation/ Repair Compliance

Certificate No.
 Certificate Expiry.....(Minimum three years, maximum ten years.)
 Job/File No(Engineer must record in a Bolster attachment code register.)
 Vehicle Make Vehicle Model
 Vehicle Registration No.....(Not required for new entry vehicles.)
 Vehicle Chassis/VIN No.
 Owner
 Maximum Payload of Logs Allowable on Vehicle
 Maximum Vehicle Mass Allowable When Carrying Logs
 Applicable Certificate of Design Compliance
 Applicable Certificate of Manufacture Compliance
 Installation Specification followed
 Bolster attachments do/ do not (delete one) rely on secondary attachment devices.

Bolster type and location	Bolster Serial No	Bolster attachment serial no	Load cell serial no	Drawing Number/ Numbers	Bolster attachment expiry date*	Maximum Log Load Permitted in Bolster (kg)

*Date of certification expiry for bolster attachment as a whole.
 This is to certify that the bolster attachments identified above comply with the requirements of the Bolster Attachment Code. (Bolster Attachment Code refers to the Log Transport Safety Committee, Bolster Attachment Code (Latest version).)
 The only standards and codes of practice used are those referenced in the Bolster Attachment Code.

Certificate No..... Page 1 of 2 Signed.....

- 1.1 I have clearly established that all of the design required in accordance with the Bolster Attachment Code has been carried out.
- 1.2 I have sound reason to believe that I have fully understood all of the designers and manufacturers intentions and requirements.
- 1.3 The installation is in accordance with the Bolster Attachment Code, and as detailed in drawings and instructions.
- 1.4 I have inspected the complete bolster attachment installation/ repair (delete as applicable) on the above vehicle. Visual inspection indicates that all work complies with the codes, standards, instructions and drawings.
- 1.5 All the bolster attachment designer's installation instructions and drawings are held in the above file.
- 1.6 All welding complies with NZS 1554 and/or any NZTA endorsed welding publication.
- 1.7 Bolster attachment components with a shorter life than bolster attachment as a whole are as the following table:-

Bolster Attachment Serial Number	Components	Scheduled replacement Interval	Replacement Made by	Date Replacement Made	Signature

*The Bolster serial number is issued by the bolster manufacturer.
 The designer shall identify the components.
 Designer to state component life. Installer to state replacement date.
 Modifications are design changes, and require a new Certificate of Compliance.*

Installation/ Repair Company

Welder NameWelder Number

Signed Name..... Date: / /

Certifying Engineer, Category HVEL/HVML, Approval Number.....

Certificate No..... Page 2 of 2 Signed.....

No 2

Engineers or Company Letterhead - including name, physical address plus postal address, phone, fax etc

Bolster Attachment Code: Certificate of Manufacture Compliance

Certificate No.

Certificate Expiry *(Minimum three years, maximum ten years.)*

Job/File No*(Engineer must record in a Bolster attachment code register.)*

Vehicle Make Vehicle Model

Vehicle Registration No.....*(Not required for new entry vehicles.)*

Vehicle Chassis/VIN No.

Owner

Maximum Payload of Logs Allowable on Vehicle

Maximum Vehicle Mass Allowable When Carrying Logs

Applicable Certificate of Design Compliance

Design Specification followed for manufacture.....

Specification to be followed for Installation.....

Extent of Components covered by this Certificate

Bolster attachments do/ do not (delete one) rely on secondary attachment devices.

Bolster type and location	Bolster Serial No	Bolster attachment serial no	Load cell serial no	Drawing Number/ Numbers	Bolster attachment expiry date*	Maximum Log Load Permitted in Bolster (kg)

*Date of certification expiry for bolster attachment as a whole.

This is to certify that the bolster attachments identified above comply with the requirements of the Bolster Attachment Code. *(Bolster Attachment Code refers to the Log Transport Safety Committee, Bolster Attachment Code (Latest version).)*

The only standards and codes of practice used are those referenced in the Bolster Attachment Code.

Certificate No..... Page 1 of 2 Signed.....

- 1.1 These attachments will only perform to the requirement of the Bolster Attachment Code when they have been installed to the approved installation drawings and when the installation has been verified and endorsed by an approved Engineer.
- 1.2 I have clearly established that all of the design required for manufacture in accordance with the Bolster Attachment Code has been carried out.
- 1.3 I have sound reason to believe that I have fully understood all of the designers intentions and requirements.
- 1.4 The manufacture has been carried out in accordance with the Bolster Attachment Code, and as detailed in drawings and instructions.
- 1.5 I have inspected the bolster attachment components. Visual inspection indicates that manufacture complies with the codes and standards listed and with drawings.
- 1.6 All drawings (general arrangement, components, & systems), component specifications, and fabricator instructions as applicable are held in the above file.
- 1.7 Welding complies with NZS 1554 and/or any NZTA endorsed welding publication.
- 1.8 Bolster attachment components with a shorter life than bolster attachment as a whole are as the following table:-

Bolster Attachment Serial Number	Components	Scheduled replacement Interval

The Bolster serial number is issued by the bolster manufacturer.

Manufacturer

Welder NameWelder Number

Signed Name..... Date: / /

Certifying Engineer, Category HVEL/HVML, Approval Number

Certificate No.....

Page 2 of 2

Signed.....

Engineers or Company Letterhead - including name, physical address plus postal address, phone, fax etc

Bolster Attachment Code: Certificate of Design Compliance

Certificate No.

Certificate Expiry *(Minimum three years, maximum ten years.)*

Job/File No*(Engineer must record in a Bolster attachment code register.)*

Bolster Attachment Type

Drawing Numbers.....

Manufacture Specification

Installation Specification

Extent of components covered by this certificate

Extent of design covered by this certificate.....

Maximum Log Load Permitted in Bolster (kg)

Maximum Bolster Bed Height Covered by Design

Bolster Attachment Design Life.....

This is to certify that the bolster attachments identified above comply with the requirements of the Bolster Attachment Code. *(Bolster Attachment Code refers to the Log Transport Safety Committee, Bolster Attachment Code (Latest version).)*

The only standards and codes of practice used are those referenced in the Bolster Attachment Code.

- 1.1 The bolster attachments detailed above have been designed in accordance with the Bolster Attachment Code.
- 1.2 These attachments will only perform to the requirement of the Bolster Attachment Code when they have been manufactured and installed to the approved installation drawings and when the installation has been verified and endorsed by an approved Engineer.
- 1.3 All design analysis, calculations, drawings (general arrangement, components, & systems), component specifications, and fabricator instructions are held in the above file.

Certificate No..... Page 1 of 2 Signed.....

- 1.4 All installation instructions and drawings are held in the above file.
- 1.5 Bolster attachment components with a shorter life than bolster attachment as a whole are as the following table:-

Bolster Attachment Type	Components	Scheduled replacement Interval

Signed Name..... Date: / /

Certifying Engineer, Category HVEL, Approval Number

No 4

Engineers or Company Letterhead - including name, physical address plus postal address, phone, fax etc

Bolster Attachment Code: Certificate of Compliance

Certificate No.

Certificate Expiry *(Minimum three years, maximum ten years.)*

Job/File No*(Engineer must record in a Bolster attachment code register.)*

Vehicle Make Vehicle Model

Vehicle Registration No.....*(Not required for new entry vehicles.)*

Vehicle Chassis/VIN No.

Owner

Maximum Payload of Logs Allowable on Vehicle

Maximum Vehicle Mass Allowable When Carrying Logs

Bolster attachments do/ do not (delete one) rely on secondary attachment devices.

Bolster type and location	Bolster Serial No	Bolster attachment serial no	Load cell serial no	Drawing Number/ Numbers	Bolster attachment expiry date*	Maximum Log Load Permitted in Bolster (kg)

*Date of certification expiry for bolster attachment as a whole.

This is to certify that the bolster attachments identified above comply with the requirements of the Bolster Attachment Code. *(Bolster Attachment Code refers to the Log Transport Safety Committee, Bolster Attachment Code (Latest version).)*

Certificate No..... Page 1 of 4 Signed.....

The only standards and codes of practice used are those referenced in the Bolster Attachment Code.

This certificate is only valid when signed in all three locations; section 1, 2 and 3.

1 Bolster Attachment Design Certification

(Including Any Secondary Attachment Devices)

- 1.1 The bolster attachments detailed above have been designed in accordance with the Bolster Attachment Code.
- 1.2 These attachments will only perform to the requirement of the Bolster Attachment Code when they have been manufactured and installed to the approved installation drawings and when the installation has been verified and endorsed by an approved Engineer.
- 1.3 All design analysis, calculations, drawings (general arrangement, components, & systems), component specifications, and fabricator instructions are held in the above file.
- 1.4 All installation instructions and drawings are held in the above file.

Signed Name..... Date: / /
Certifying Engineer, Category HVEL, Approval Number

2 Manufacture Certification

- 2.1 I have clearly established that all of the design required for manufacture in accordance with the Bolster Attachment Code has been carried out.
- 2.2 I have sound reason to believe that I have fully understood all of the designers intentions and requirements.
- 2.3 The manufacture has been carried out in accordance with the Bolster Attachment Code, and as detailed in drawings and instructions.
- 2.4 I have inspected the bolster attachment components. Visual inspection indicates that manufacture complies with the codes and standards listed and with drawings.
- 2.5 All drawings (general arrangement, components, & systems), component specifications, and fabricator instructions as applicable are held in the above file.

Certificate No..... Page 2 of 4 Signed.....

2.6 Welding complies with NZS 1554 and/or any NZTA endorsed welding publication.

Manufacturer

Welder NameWelder Number

Signed Name..... Date: / /

Certifying Engineer, Category HVEL/HVML, Approval Number

3 Installation/ Repair Certification

- 3.1 I have clearly established that all of the design required in accordance with the Bolster Attachment Code has been carried out.
- 3.2 I have sound reason to believe that I have fully understood all of the designers and manufacturers intentions and requirements.
- 3.3 The installation is in accordance with the Bolster Attachment Code, and as detailed in drawings and instructions.
- 3.4 I have inspected the complete bolster attachment installation/ repair (delete as applicable) on the above vehicle. Visual inspection indicates that all work complies with the codes, standards, instructions and drawings.
- 3.5 All the bolster attachment designer's installation instructions and drawings are held in the above file.
- 3.6 All welding complies with NZS 1554 and/or any NZTA endorsed welding publication.

Installation/ Repair Company

Welder NameWelder Number

Signed Name..... Date: / /

Certifying Engineer, Category HVEL/HVML, Approval Number

4 Special Conditions

Bolster attachment components with a shorter life than bolster attachment as a whole.

Bolster Attachment Serial Number	Components	Scheduled replacement Interval	Replacement Made by	Date Replacement Made	Signature

The Bolster serial number is issued by the bolster manufacturer.

The designer shall identify the components.

Designer to state component life. Installer to state replacement date.

Modifications are design changes, and require a new Certificate of Compliance.

4.2

4.3.....

No. 5

Engineers or Company Letterhead - including name, physical address plus postal address, phone, fax etc

Bolster Attachment Code:

Certificate of Manufacture Compliance

Certificate No. File No.....*(manufacturer)/.....(certifier)

This is to certify that I have inspected the bolster attachment components manufactured by.....as identified below. Visual inspection indicates that manufacture has been carried out in strict accordance with the design requirements of Certificate of Component Design Compliance numberwhich covers bolster attachment components built to(drawing issuer) drawing number

Job number..... Date of manufacture.....

Description of component
.....
.....
.....

Component Serial Numbers*.....
.....
.....
.....

Compliance Conditions and Explanatory Notes

- *1 The manufacturer’s certifying engineer must record the above file and serial numbers in a Bolster Attachment Code register.
- 2. Bolster Attachment Code refers to the LTSA-approved Log Transport Safety Committee Bolster Attachment Code.
- 3. These attachment components will only comply with the requirement of the Bolster Attachment Code when they have been installed to the approved installation drawings as part of a complete bolster-to-chassis attachment system and when the installation has been verified and endorsed by an approved Engineer.
- 4. I have established that all of the requirements specified in the design documents have been carried out and that the designer’s drawings and requirements have been clearly understood by the manufacturer and the manufacturer’s certifying engineer.

Certificate No..... Page 1 of 2 Signed.....

- 5. All drawings (general arrangement, components, & systems), component specifications, fabricator instructions, records of manufacture & inspection as applicable are held in the above file(s).
- 6. Welding complies with NZS 1554 and/or any NZTA endorsed welding publication.

Welder Names and NZS 1554

numbers.....

I have fully understood and carried out all of the above requirements.

Signed Name..... Date: / /

Certifying Engineer, Category HVEL/HVML, Approval Number

Design certifier/Manufacturer copy **No. 6**

Engineer's or Company Letterhead – including name, physical address plus postal address, phone, fax, etc

Bolster Attachment Code

Certificate of Design Compliance

Certificate No.

This certificate covers the design of the rigid/resilient/sliding/torsionally independent (*delete not applicable*) logging bolster attachment components as detailed on Drawing Number(s)

for manufacture by.....

All Manufacturing, Installation and Operational instructions relevant to the above component design are specified in the above drawing(s).

All design analysis, calculations, drawings (general arrangement, components, & systems), component specifications, and fabricator instructions are held in Job/File No.....at
.....(*Engineer must record in a Bolster Attachment Code register.*)

Bolster attachment group description.....
.....
.....

Extent of components covered by this certificate

Extent of design covered by this certificate.....

Bolster base dimensions approved for use with this design:-
width..... height (*Refer to the above drawing for further details of bolster compatibility requirements.*)

This design is approved for use in conjunction with loadcell make & model number (if applicable):.....

Maximum Certificate Life of a bolster attachment containing any components built to this design isyears

Design Life of a bolster attachment containing any components built to this design isyears

(Minimum three years, maximum ten years.)

Certificate No.....Page 1 of 3 Signed.....

Maximum Log Load Permitted in Bolsterkg (note that this may be further limited by the nature of the total bolster attachment system in which the component design is used – refer to installation certificate)

This certificate is valid for use by the above designated manufacturer until or until any revision of the current Bolster Attachment Code dated (whichever is sooner), after which time no new components may be manufactured under this certificate until the design has been reassessed by an HVEL engineer and re-certified.

I,, hereby certify (not to be construed as a guarantee) that the bolster attachment component design as identified above complies with the requirements of the Bolster Attachment Code and all standards and codes of practice referred to therein, subject to the following conditions.

Note

1. Bolster Attachment Code refers to the LTSA-approved Log Transport Safety Committee Bolster Attachment Code.
2. This certificate covers the design only of a component or components of a total bolster attachment system. The attachment component(s) has/have been designed to be manufactured and installed as part of a complete bolster attachment system which will comply with the Bolster Attachment Code only when this and all other components of the system have been separately certified as being designed, manufactured and installed in accordance with the Code by an approved HVEL Engineer.
3. This certificate is therefore invalid unless accompanied by (a) a certificate of manufacture for any component built to the above drawing and (b) a certificate of compliance (with original signature of installation certifier) covering the installation of that component on a vehicle, including any design and manufacture work involved in the installation.
4. Any change or revision to the above drawing or its sub-drawings or specifications invalidates this certificate for new construction.
5. Any change to the above drawing or its sub-drawings or specifications must be approved by a HVEL certifying engineer and a new design certificate issued.
6. The following table specifies parts belonging to the above bolster attachment component(s) which have a shorter design life than stated above:- (also included are any short-life items which interface to the above certified components e.g. bolts).

Certificate No.....

Page 2 of 3

Signed.....

<i>Part</i>	<i>Scheduled replacement Interval</i>	<i>Replacement instructions</i>

- 7. Acceptance of this certificate by the manufacturer and/or manufacturing certifier implies an obligation to inform the original design certifying engineer of any manufacturing problems, in-service defects or failures which may arise.
- 8. The above drawing number(s) are issued by
- 9. An original of this design certificate must be held by the manufacturer and will be invalid for new manufacture of components to the above design without the design certifier's and manufacturer's original signatures below.

.....

Signed Print full Name.....Date:...../...../.....
 Certifying Engineer, Category HVEL, Approval Number

I,of(manufacturer)
 hereby accept the terms and conditions of the above certificate.

Signed..... Date...../...../.....

Design certifier/Manufacturing certifier/Installation certifier/Owner/VTNZ copy

No. 7

Engineers or Company Letterhead - including name, physical address plus postal address, phone, fax etc

Bolster Attachment Code:

Certificate of Compliance

Certificate No.

Certificate Expiry*Minimum is three years from date of issue, maximum ten years. (Date of certification expiry for vehicle bolster attachment installation as a whole, excluding any short-life components listed in Table C)*

Certifier's Job/File No*(Engineer must record in a Bolster Attachment Code register.)*

Vehicle Make & Model

Registration No.....Chassis/VIN No.

Owner

Maximum Payload of Logs Allowable on Vehicle (kg).....

Maximum Vehicle Mass Allowable When Carrying Logs (kg)

Table A: Vehicle Bolster attachment systems

Bolster type and location	Bolster Serial No	Design relies on Secondary Attachment device(s) (yes/no)	Drawing Number/Numbers specifying manufacturing, installation and operating instructions for total bolster to chassis attachment.	Log Payload Rating per Bolster (kg)

In the event of replacement of individual bolsters attachments, individual lines may be crossed out in the above table but a new compliance certificate must be issued for the replacement bolster attachment.

Certificate No.....

Page 1 of 5

Signed.....

Notes:.....

This is to certify that the bolster attachments identified above comply with the requirements of the Bolster Attachment Code and all standards and codes of practice referred to therein. (Bolster Attachment Code refers to the LTSA-approved Log Transport Safety Committee Bolster Attachment Code, current version.)

This certificate is only valid when signed in all three sections 1, 2 and 3.

1 Bolster Attachment Design Certification

(Including any Secondary Attachment Devices)

- 1.1 I have designed the bolster attachment systems detailed in Table A above, (except for those pre-certified components or subassemblies covered in Table B), in accordance with the Bolster Attachment Code.
- 1.2 These attachments will only comply with the requirements of the Bolster Attachment Code when they have been manufactured and installed to the approved installation drawings and when the installation has been verified and endorsed by an HVEL-approved Engineer.
- 1.3 All design analysis, calculations, drawings (general arrangement, components, & systems), component specifications, and fabricator instructions are held in the above file.
- 1.4 All installation instructions and drawings are held in the above file.
- 1.5 Separate certificates of design are attached covering the design of the following components or subassemblies used in above bolster attachments:

Table B: Pre-Certified Components or subassemblies

Bolster serial number	Bolster attachment component drawing number	Bolster attachment component description and extent of design covered	Manufacturer of pre-certified components	Component serial numbers

Certificate No.....Page 2 of 5 Signed.....

- 1.6 All the component or subassembly designer's recommendations, instructions and drawings for the interface of any Table B components with the bolster attachment systems listed in Table A have been complied with insofar as the design of the bolster attachment as a whole is concerned. All such recommendations, instructions and drawings are held on the above file.
- 1.7 Modifications are design changes, and require a new Certificate of Compliance.

Signed
 Name..... Date:/...../.....

Certifying Engineer, Category HVEL, Approval Number

2 Manufacture Certification

Manufacturer Manufacturer's job number.....

Welder Name(s) and NZS 1554 number(s).....

- 2.1 I have clearly established that all of the design required for manufacture in accordance with the Bolster Attachment Code has been carried out.
- 2.2 I have sound reason to believe that I have fully understood all of the designers intentions and requirements.
- 2.3 The manufacture has been carried out in accordance with the Bolster Attachment Code, and as detailed in the design certifier's drawings and instructions.
- 2.4 I have inspected the bolster attachment components. Visual inspection indicates that manufacture complies with the drawings listed in Table A.
- 2.5 All manufacturing drawings (general arrangement, components, & systems), component specifications, fabricator instructions, inspection records & photographs as applicable are held in file
(Engineer must record in a Bolster Attachment Code register)
- 2.6 Welding complies with NZS 1554 and/or any NZTA endorsed welding publication.
- 2.7 Separate certificates of manufacture are attached covering any pre-certified subassemblies or components identified in Table B which have been used in the above bolster attachments.

Signed.....
 Name..... Date:/...../.....

Manufacturer Certifying Engineer, Category HVEL/HVML, Approval Number

Certificate No..... Page 3 of 5 Signed.....

3 Installation/Repair Certification

Installation/ Repair Company

Installation Company File NoInstallation company job no.....

Welder Name(s) and NZS 1554 Number(s)

- 3.1 I have clearly established that all of the design required in accordance with the Bolster Attachment Code has been carried out.
- 3.2 I have sound reason to believe that I have fully understood all of the designers and manufacturers intentions and requirements.
- 3.3 The installation is in accordance with the Bolster Attachment Code, and as detailed in the installation drawings and instructions specified in Table A.
- 3.4 I have inspected the complete bolster attachment installation/ repair (delete as applicable) on the above vehicle. Visual inspection indicates that all work complies with the codes, standards, instructions and drawings.
- 3.5 All the bolster attachment designer’s installation instructions and drawings, and installation inspection records are held in Installation Certifier’s File no.....(*Engineer must record in a Bolster Attachment Code register.*)
- 3.6 All welding complies with NZS 1554 and/or any NZTA endorsed welding publication.

Table C: Bolster attachment components with a shorter life than bolster attachment as a whole.

Bolster Serial Number	Bolster attachment components	Scheduled replacement date	Replace-ment carried out by	Date replace-ment carried out	Signature

**The Bolster serial number is issued by the bolster manufacturer.*

***The installation certifying engineer shall identify bolster, components, replacement dates. Continue on separate sheet if necessary.*

****Company carrying out replacement shall obtain and follow all replacement instructions from the installation company.*

Certificate No..... Page 4 of 5 Signed.....

Notes.....
.....
.....

SignedName..... Date:/...../.....

Installation Certifying Engineer, Category HVEL/HVML, Approval Number ...

Engineers or Company Letterhead - including name, physical address plus postal address, phone, fax etc

No 8

**STATEMENT OF COMPLIANCE WITH
TYPE APPROVED DESIGN**

Certificate No.

Job/Project File Reference:

Vehicle Details : Make.....

Model.....

VIN.....

Operator Details :

Iof hereby certify that the bolster attachment system / individual bolster attachment (*delete one*) detailed in drawing(s):

.....

..... and incorporated in the above vehicle is in accordance with the requirements of section 6.4.1 of the Bolster Attachment Code Revision 2 November 2010.

Bolster attachments of the particular design and construction have successfully completed in excess of 250,000 kilometres on a single vehicle. Details of this reference vehicle are recorded in the above job/project file.

Date of expiry of this certificate:

Signed..... Date.....

HVEL/HVML Certifier ID.....”