

Load restraints

10-1 Load anchorages

10-2 Stock crates and stock crate retention devices

10-3 Log bolsters

10-4 Headboards, sideboards and tailboards

10-5 Curtain systems

Load restraint 10-1 Load anchorages

Summary of legislation

Applicable legislation

- Land Transport Rule: Heavy Vehicles 2004
- New Zealand Standard 5444: 1989, Load Anchorage Points for Heavy Vehicles
- New Zealand Standard 5444: 2005, Load Anchorage Points for Heavy Vehicles

Mandatory requirement

1. Load anchorage points (hooks, rope rails, twist locks, tie-down rings, keyhole plates and chain slots) must comply and be certified to NZS 5444.

Mandatory equipment

2. A trailer that is constructed to transport a load must be fitted with load-securing equipment (**Note 1**).
3. A trailer must have load anchorage points that are certified by an HVS certifier as complying with New Zealand Standard 5444, unless the trailer is one of the following:
 - a) a trailer fitted with a body that is specifically designed to contain the transported load without the use of lashings, chains or other devices, such as a tank body or a tipping body for transporting bulk goods (refer to section 3-1), or
 - b) a trailer fitted with a stock crate and stock crate retention devices (refer to section 10-2), or
 - c) a curtain-sided body fitted with a load-rated curtain and curtain anchorage system (refer to section 10-5), or
 - d) a trailer fitted with logging bolsters (refer to section 10-3).
4. A load anchorage must be certified by an HVS certifier of category HVIA, HVMA or HVEA.

Condition

5. A certification label or plate must be:
 - a) clearly and indelibly marked, and
 - b) securely attached.
6. Load securing equipment that is fitted to a vehicle must be constructed to ensure that the load can be securely contained on the vehicle under all conditions of loading and operation for which the vehicle was constructed.

Modification and repair

7. A modification or repair that affects a load anchorage point must be inspected and certified by an HVS certifier of category HVEA, HVMA or HVIA, unless the vehicle:
 - a) is excluded from the requirement for HVS certification (**Table 10-1-2**), and
 - b) has been inspected in accordance with the requirements in this manual, including those for equipment, condition and performance.

Reasons for rejection

Mandatory requirements

1. A load anchorage point does not have evidence of certification to NZS 5444, ie:
 - a) the load anchorage point was fitted before the last CoF inspection, and after 1 January 1997, and no LANDATA record has been entered, or

Note Before 1 January 1997 certification was required but for inspection purposes the LANDATA record need not be checked
 - b) the load anchorage point was fitted after the last CoF inspection and
 - i. a valid LT400 form has not been presented, or
 - ii. the HVS certifier was not of category HVEA, HVMA, HVIA, or
 - c) there is no valid certification label or plate attached to the vehicle (usually fitted to the left-hand chassis or coaming rail, or to the load platform) as specified in **Table 10-1-1**.

Mandatory equipment

2. A trailer constructed to transport a load is not fitted with load anchorage points (hooks, rope rails, twist locks, tie-down rings, keyhole plates or chain slots), unless the trailer is one of the following:
 - a) a trailer fitted with a body that is specifically designed to contain the transported load without the use of lashings, chains or other devices, such as a tank body or a tipping body for transporting bulk goods (refer to section 3-1)
 - b) a trailer fitted with a stock crate and stock crate retention devices (refer to section 10-2)
 - c) a curtain-sided body fitted with a load-rated curtain and curtain anchorage system (refer to section 10-5)
 - d) a trailer fitted with logging bolsters (refer to section 10-3).

Condition

3. A certification label or plate:
 - a) is not indelibly marked, or

Load restraint

10-1 Load anchorages (cont.)

Reasons for rejection

- b) is illegible, or
 - c) is attached so that it is not easily visible, or
 - d) has details that do not match the vehicle, or
 - e) has obvious signs of tampering.
4. A load anchorage component:
- a) is missing, or
 - b) is not securely attached, or
 - c) is cracked or deformed, or
 - d) has significant corrosion damage, or
 - e) is worn beyond manufacturer’s specifications.

Modification and repair

5. A modification or repair affects a load anchorage or its attachment and:
- a) is not excluded from the requirements for HVS certification (**Table 10-1-2**), or
 - b) is not for the purpose of law enforcement or the provision of emergency services, or
 - c) is missing proof of HVS certification, ie:
 - i. the vehicle was modified or repaired before the last CoF inspection and no LANDATA record has been entered, or
 - ii. the vehicle was modified or repaired since the last CoF inspection and no valid LT400 form from an HVS certifier of category HVEA, HVMA or HVIA has been presented.

Table 10-1-1. Minimum certification label and plate details required

NZS 5444: 1989	NZS 5444: 2005
Identity of the manufacturer Rated capacity of the load anchorage points	Certificate number HVS identifier Number and capacity of each type of load anchorage point fitted VIN or chassis number Any special conditions if applicable Note Any label or plate issued on or after 1 June 2005 must contain the above information

Table 10-1-2. Requirements for HVS certification

HVS certification is required	HVS certification is not required
1. Fitting of load anchorages.	1. Repairs to coaming rails that do not support certified load anchorage points or J-hooks. 2. A vehicle fitted with a bin lifting and hooking mechanism does not require HVS certification to NZS 5444, but the bin must be able to be secured safely using a fail-safe system. This may include a hydraulically operated and locked hook or similar, provided the locking device can only be opened by applying a positive and definitive hydraulic pressure. 3. Tarpaulin hooks and load restraints fitted inside a box- or van-type body, eg to restrain furniture, are not considered to be load anchorages and therefore do not require HVS certification (it is recommended that tarpaulin hooks and rails are identified to be used only for retaining tarpaulins). 4. Any modification or repair likely to have been carried out before 1 January 1997 (modifications and repairs before this date generally required certification but for inspection purposes the LANDATA record need not be checked). 5. Any repair or modification not listed in the left-hand column unless the vehicle inspector considers that certification is required because the modification or repair has affected the vehicle's safety performance (a second opinion from an expert may be needed, eg the manufacturer's representative, or a reputable workshop).

Note 1 Load-securing equipment means equipment or a device permanently fitted to a vehicle to secure, either by itself or in conjunction with other equipment or devices such as lashings, a load to a vehicle.

Load anchorage point means a device permanently attached to a vehicle to enable a load to be secured or attached to the vehicle.

Load restraint

10-2 Stock crates and stock crate retention devices

Summary of legislation

Applicable legislation

- Land Transport Rule: Heavy Vehicles 2004
- New Zealand Standard 5413: 1993, Code of Practice for the Manufacture and Use of Stock crates on Heavy Vehicles
- New Zealand Standard 5444: 1989, Load Anchorage Points for Heavy Vehicles
- New Zealand Standard 5444: 2005, Load Anchorage Points for Heavy Vehicles

Mandatory equipment

1. A monocoque stock trailer with a GVM of 6000 kg or more, or a stock crate and its retention devices, if fitted to a vehicle with a GVM of 6000 kg or more, must be constructed in accordance with NZS 5413.
2. Stock crate anchorage points fitted to the deck of a vehicle must comply with and be certified to NZS 5444.
3. Stock crate retention devices must be attached to the crate structure so as to transmit the restraint forces to the vehicle load platform or basic vehicle structure.

Condition

4. External doors shall be firmly fixed to prevent stock from being ejected onto the roadway.
5. Load securing equipment must be constructed to ensure that the load can be safely contained on the vehicle under all conditions of loading and operation for which the vehicle was constructed.

Modification and repair

6. A modification or repair that affects a stock crate anchorage point must be inspected and certified by an HVS certifier of category HVEA, HVMA or HVIA, unless the vehicle:
 - a) is excluded from the requirement for HVS certification (**Table 10-2-2**), and
 - b) has been inspected in accordance with the requirements in this manual, including those for equipment, condition and performance.

Reasons for rejection

Mandatory equipment

1. A monocoque stock trailer with a GVM of 6000 kg or more, or a stock crate, including its retention devices (**Figure 10-2-1**), fitted to a vehicle with a GVM of 6000 kg or more, has no manufacturer's plate certifying construction in accordance with NZS 5413, that specifies at least all of the following details as appropriate:
 - a) company name, and
 - b) stock crate serial number, and
 - c) date of manufacture of stock crate, and
 - d) restraint capacity total in kilograms, and
 - e) restraint capacity individual in kilograms, and
 - f) number of restraints per side.
2. Stock crate anchorage points fitted to the deck have not been certified to NZS 5444, ie:
 - a) the stock crate anchorage points were fitted before the last CoF inspection, and after 1 January 1997, and there is no LANDATA record, or

Note Before 1 January 1997 certification was required but for inspection purposes the LANDATA record need not be checked
 - b) the stock crate anchorage points were fitted after the last CoF inspection and:
 - i. a valid LT400 form is not presented, or
 - ii. the HVS certifier was not of category HVEA, HVIA or HVMA, or
 - iii. there is no valid certification plate/label attached to the vehicle as required in **Table 10-2-1**.

Condition

3. A certification label or plate:
 - a) is not indelibly marked, or
 - b) is illegible, or
 - c) is attached so that it is not easily visible, or
 - d) has details that do not match the vehicle, or
 - e) has obvious signs of tampering.

Reasons for rejection

4. The stock crate's external doors:
 - a) are not securely attached to the stock crate body, or
 - b) do not remain secure in a closed or locked position.
5. A J-hook assembly or other retention device, or an anchorage point:
 - a) is not securely attached, or
 - b) has a bush, fastener, washer, J-hook or other component missing or significantly corroded, or
 - c) is cracked or distorted, or
 - d) has cracks or corrosion damage on the stock crate within 150 mm of the retention device attachment point, or
 - e) is not of a type suitable for retaining the stock crate, or
 - f) is worn beyond manufacturer's specifications.

Modification and repair

6. A modification or repair affects the stock crate or its retention devices and:
 - a) is not excluded from the requirements for HVS certification (**Table 10-2-2**), or
 - b) is not for the purpose of law enforcement or the provision of emergency services, or
 - c) is missing proof of HVS certification, ie:
 - i. the vehicle was modified or repaired before the last CoF inspection and no LANDATA record has been entered, or
 - ii. the vehicle was modified or repaired since the last CoF inspection and no valid LT400 form from an HVS certifier of category HVEA, HVMA or HVIA has been presented.

**Table 10-2-1. Minimum certification label and plate details required**

NZS 5444: 1989	NZS 5444: 2005
Identity of the manufacturer Rated capacity of the load anchorage points	Certificate number HVS identifier Number and capacity of each type of load anchorage point fitted VIN or chassis number Any special conditions if applicable Note Any label or plate issued on or after 1 June 2005 must contain the above information

Table 10-2-2. Requirements for HVS certification

HVS certification is required	HVS certification is not required
1. Stock crate retention devices that have been modified or repaired resulting in altered load ratings.	<ol style="list-style-type: none"> 1. A stock crate retention device has been repaired or modified, and the HVS certifier can confirm that the load ratings are still correct. 2. Any modification or repair likely to have been carried out before 1 January 1997 (modifications and repairs before this date generally required certification but for inspection purposes the LANDATA record need not be checked). 3. Any repair or modification not listed in the left-hand column unless the vehicle inspector considers that certification is required because the modification or repair has affected the vehicle's safety performance (a second opinion from an expert may be needed, eg the manufacturer's representative, or a reputable workshop).

Note 1 Body means that part of the vehicle that is designed for the use and accommodation of the occupants or to hold any goods. Comprised of the load platform/deck, headboard, sideboards, tailgate, coaming rails, cross members, runners and attachment to the chassis.

Chassis means the structural lower part of a vehicle to which the running gear and, as applicable, engine, transmission, steering system and body may be attached.

J-hook means a retention device fabricated from metal for the retention of stock crates to the vehicle load platform, mounted in such a way as to be fixed either inside or outside the coaming rail vertically and tensioned through a bush on the crate structure by way of a threaded fastener.

Load anchorage point means a device permanently attached to a vehicle to enable a load to be secured or attached to the vehicle.

Monocoque in relation to a vehicle, means that the chassis of the vehicle is integral to the body.

Load restraint

10-2 Stock crates and stock crate retention devices (cont.)

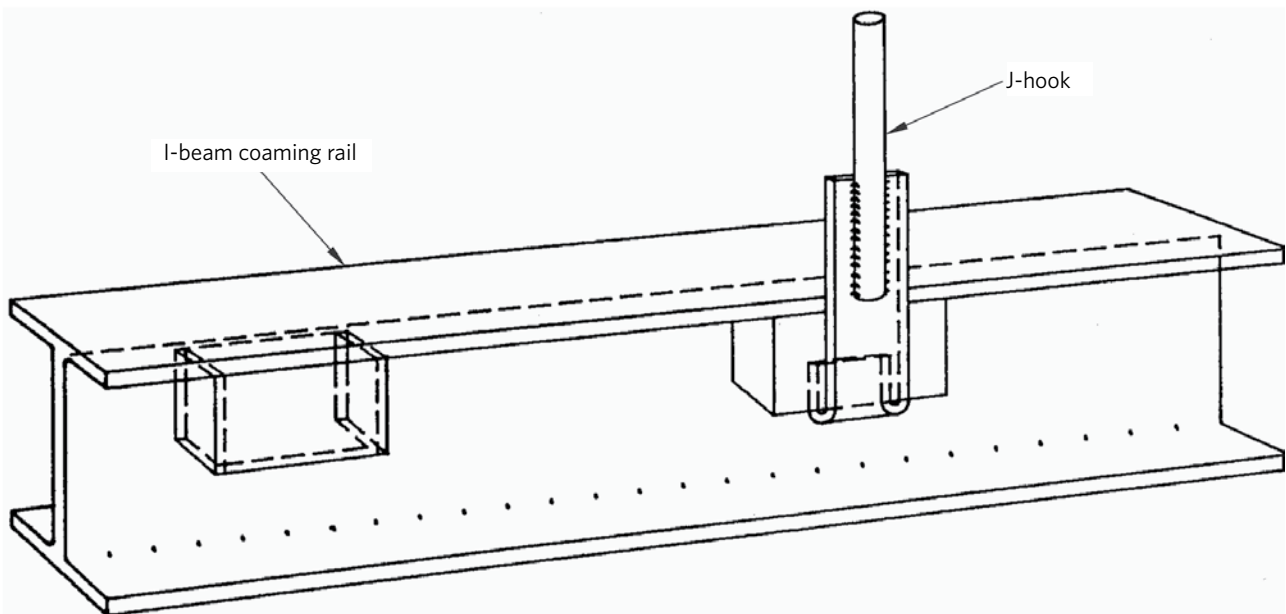
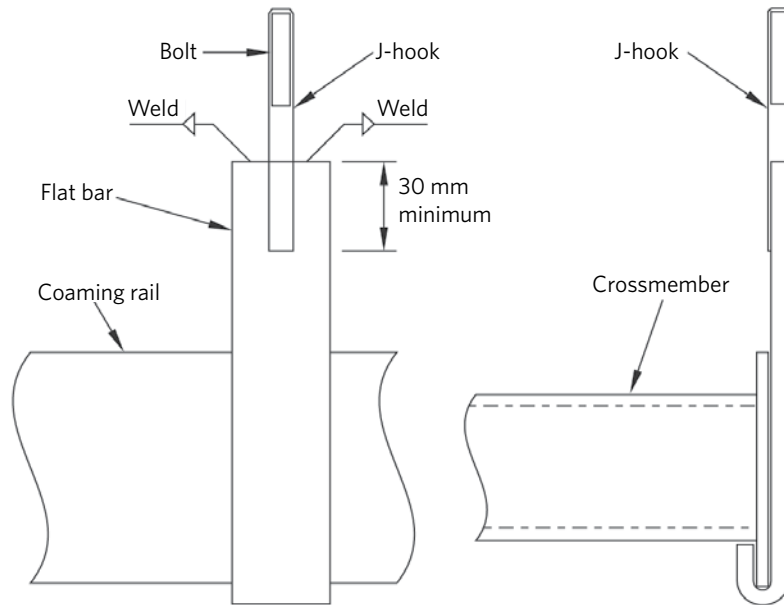

Figure 10-2-1. Acceptable types of J-hooks

Load restraint 10-3 Log bolsters

Summary of legislation

Applicable legislation

- Land Transport Rule: Heavy Vehicles 2004
- Bolster Attachment Code, issue 27 November 1998
- Bolster Attachment Code, issue 1 May 2001
- Bolster Attachment Code, issue 2 November 2010
- *New Zealand Gazette*, 14 January 1999, issue 1, page 64
- *New Zealand Gazette*, 27 May 1999, issue 60, page 1431
- *New Zealand Gazette*, 26 April 2001, issue 43, page 957

Mandatory requirement

1. A logging bolster attachment fitted to a vehicle must comply with the requirements in **Table 10-3-1**.
2. Certification of a logging bolster attachment must be certified by an HVS certifier of category HVIL, HVML or HVEL.

Mandatory equipment

Bolster Attachment Code, issue 27 November 1998

3. Individual bolsters must be stamped, indelibly labelled or marked to clearly identify the:
 - a) bolster manufacturer, and
 - b) bolster serial number, and
 - c) rated bolster load.
4. The vehicle must be fitted, on the left-hand side chassis rail as far as is practicable in line with the front of the coaming rail, with at least one tag identifying the:
 - a) bolsters, and
 - b) bolster attachment, and
 - c) vehicle, and
 - d) expiry date.

Bolster Attachment Code (issue 1 May 2001 or issue 2 November 2010)

5. Individual bolsters must be stamped, indelibly labelled or marked to clearly identify their serial number.
6. Individual bolster mounts must be stamped, indelibly labelled or marked to clearly identify their serial number.
7. The vehicle must be fitted with at least one tag identifying the bolsters, bolster attachments, bolster rating, the HVS certifier, the bolster manufacturer, the vehicle and the expiry date.

Condition

8. Load-securing equipment that is fitted to a vehicle must be constructed to ensure that the load can be securely contained on the vehicle under all conditions of loading and operation for which the vehicle was constructed.

Reasons for rejection

Mandatory requirement

1. A logging bolster attachment fitted to a vehicle that is required to be certified in **Table 10-3-1** does not have evidence of certification.
2. A logging bolster attachment fitted to a vehicle certified to the Bolster Attachment Code (issue 1 May 2001 or issue 2 November 2010) does not have evidence of certification, ie:
 - a) the attachment was fitted before the last CoF inspection and there is no LANDATA record of the certification, or
 - b) the attachment was fitted after the last CoF inspection and:
 - i. a valid LT400 form is not presented, or
 - ii. the HVS certifier was not of category HVEL, HVIL or HVML.
 - c) individual bolsters are not stamped, indelibly labelled or marked to clearly identify their serial numbers, or
 - d) individual bolster attachments are not stamped, indelibly labelled or marked to clearly identify their serial numbers, or
 - e) the vehicle is not fitted on the left-hand chassis rail with at least one tag clearly identifying the bolsters, bolster attachments, bolster rating, HVS certifier, bolster manufacturer, vehicle and expiry date.
3. A logging bolster attachment fitted to a vehicle certified to the Bolster Attachment Code (issue 27 November 1998) does not have evidence of certification, ie:
 - a) there is no LANDATA record of the certification, or
 - b) individual bolsters are not stamped, indelibly labelled or marked to clearly identify the bolster manufacturer, bolster serial number and rated bolster load, or
 - c) the vehicle is not fitted on the left-hand chassis rail with at least one tag to clearly identify the bolsters, bolster attachment, vehicle and expiry date.

Load restraint

10-3 Log bolsters (cont.)

9. A load-bearing structure must be of adequate strength for all conditions and loading for which the vehicle was constructed.

Modification and repair

10. A modification or repair that affects a log bolster attachment must be inspected and certified by an HVS certifier of category HVEL, HVML or HVIL, unless the vehicle:
 - a) is excluded from the requirement for HVS certification (**Table 10-3-2**), and
 - b) has been inspected in accordance with the requirements in this manual, including those for equipment, condition and performance.

Reasons for rejection

4. A logging bolster attachment on a long log logging vehicle fitted with a convertible (sliding or folding) bolster does not have evidence of certification required in **Table 10-3-1**, ie there is no LANDATA record of the certification.

Condition

5. A required certification label, plate or marking:
 - a) is illegible, or
 - b) is incorrect, eg serial numbers differ between the label and the bolsters, or
 - c) has expired.
6. A log bolster or log bolster mounting, including a component such as a load cell, weld and fastener:
 - a) is missing, or
 - b) is not securely attached, or
 - c) is cracked or deformed, or
 - d) has significant corrosion damage, or
 - e) is worn beyond manufacturer's specifications, or
 - f) has excessive wear between mating surfaces.
7. A sliding bolster locking device is:
 - a) missing, or
 - b) not effective, or
 - c) of an unacceptable type, eg air or hydraulic slide cylinder or chain drives.

Modification and repair

8. A modification or repair affects the log bolster or its attachment and:
 - a) is not excluded from the requirements for HVS certification (**Table 10-3-2**), or
 - b) is not for the purpose of law enforcement or the provision of emergency services, or
 - c) is missing proof of HVS certification, ie:



Reasons for rejection

- i. the vehicle was modified or repaired before the last CoF inspection and no LANDATA record has been entered, or
- ii. the vehicle was modified or repaired since the last CoF inspection and no valid LT400 form from an HVS certifier of category HVEL, HVML or HVIL has been presented.

Table 10-3-1. Logging bolster attachment certification requirements

Fitted before 1 October 1999	Fitted 1 October 1999-30 April 2001	Fitted from 1 May 2001-30 September 2011	Fitted from 1 October 2011
No certification	Either Bolster Attachment Code (issue 27 November 1998), or Bolster Attachment Code (issue 1 May 2001), or optional for convertible bolsters on long-log logging vehicles: <ul style="list-style-type: none"> ▪ certification that the same design of bolster attachments has successfully completed 250,000 km of service on a single vehicle without indications of fatigue or failure. 	All bolster attachments: Bolster Attachment Code (issue 1 May 2001) or optional for convertible bolsters on long-log logging vehicles: <ul style="list-style-type: none"> ▪ certification that the same design of bolster attachments has successfully completed 250,000 km of service on a single vehicle without indications of fatigue or failure. 	All bolster attachments: Bolster Attachment Code (issue 2 November 2010) or optional for convertible bolsters on long-log logging vehicles: <ul style="list-style-type: none"> ▪ certification that the same design of bolster attachments has successfully completed 250,000 km of service on a single vehicle without indications of fatigue or failure.

Load restraint 10-3 Log bolsters (cont.)

Table 10-3-2. Requirements for HVS certification

HVS certification is required	HVS certification is not required
<p>1. Any repairs to the bolster attachments.</p>	<p>1. Where a fastener fails the inspection, the CoF inspector must request a written report from an HVS certifier of category HVEL, HVML or HVIL who will disassemble the fasteners and confirm that:</p> <ul style="list-style-type: none"> a) movable parts such as lock pins have been checked for proper operation and engagement, and b) mating parts seat correctly, and c) fasteners have been fitted to manufacturer’s specifications and bolt torques are correct, and d) any other manufacturer’s requirements have been complied with. <p>2. Any modification or repair likely to have been carried out before 1 January 1997 (modifications and repairs before this date generally required certification but for inspection purposes no evidence of this is required).</p> <p>3. Any repair or modification not listed in the left-hand column unless the vehicle inspector considers that certification is required because the modification or repair has affected the vehicle’s safety performance (a second opinion from an expert may be needed, eg the manufacturer’s representative, or a reputable workshop).</p>

Note 1 A convertible bolster is usually slid to a different position or dropped down to allow long logs to span two trailers.

Note 2 Logging bolster means a vertically orientated member attached to a vehicle that is used to secure loads of timber logs.

Load restraint**10-4 Headboards, sideboards and tailboards****Summary of legislation****Applicable Legislation**

- Land Transport Rule: Heavy Vehicles 2004

Condition

1. A headboard, sideboard or tailboard fitted to a vehicle for the purpose of restraining a load on that vehicle must be of adequate strength to withstand load forces without incurring permanent deformation.
2. A headboard, sideboard or tailboard must be fitted to a vehicle in a way that ensures that the parts of the vehicle to which it is attached are able to withstand the forces exerted by the headboard, sideboard or tailboard without incurring permanent deformation.

Reasons for rejection**Condition**

1. A headboard, sideboard or tailboard:
 - a) is not securely attached, or
 - b) has a fastener that is missing or loose, or significantly corroded, or
 - c) is cracked or significantly distorted or corroded.

Note 1 Headboard means the substantially vertical part of the forward end of a flat-deck or curtain-sided body of a vehicle.

Sideboard means the substantially vertical part of the side of a flat-deck body of a vehicle.

Tailboard means the substantially vertical part of the rear end of a flat-deck or curtain-sided body of a vehicle.

Load restraint 10-5 Curtain systems

Summary of legislation

Applicable legislation

- Land Transport Rule: Heavy Vehicles 2004

Mandatory equipment

- If a vehicle has a curtain-sided body that is constructed to secure a load on a vehicle, each curtain and curtain anchorage system must:
 - have a manufacturer's load rating appropriate for all conditions of loading and operation of the vehicle, and
 - be clearly marked with the manufacturer's load rating in kilograms per metre, in a position on the curtain that is readily accessible for inspection purposes.

Condition

- Load-securing equipment that is fitted to a vehicle must be constructed to ensure that the load can be securely contained on the vehicle under all conditions of loading and operation for which the vehicle was constructed.

Reasons for rejection

Condition

- A load-rated curtain (**Notes 1 and 2**):
 - is ripped, or
 - has deteriorated, resulting in weakening of the curtain material, eg crazing, brittleness or stiffness, or
 - has become detached from the frame, or
 - has been poorly repaired.
- A load-rated curtain tensioning system component:
 - is missing, or
 - is not securely attached, or
 - is damaged, cracked or deformed, or
 - has significant corrosion damage, or
 - is worn beyond manufacturer's specifications, or
 - does not function correctly.
- A non-load-rated curtain has deteriorated such an extent that parts could come loose (**Note 3**).

Note 1 For the purposes of this inspection, a load-rated curtain is one that has labelling that includes the manufacturer's load rating in kilograms per metre.

Note 2 Advice from the curtain manufacturer may be required in case of doubt about damage and deterioration limits and quality of repairs.

Note 3 For curtain siders that are not load rated, refer to section 10-1 Load anchorages for requirements.

